

Wall mount unit for LCD projectors

Model name **HAS-WM03**

User's Manual

ENGLISH

Thank you for purchasing a wall mount unit specially designed for Hitachi LCD projectors. Be sure to read this manual and the User's Manual supplied with the LCD projector before use so you will know how to install it properly. After you have finished reading these documents, put them away in a safe place for future reference.

Disclaimer



- The content of this manual and the specifications of the product it describes are subject to change without prior notice.
- Note that Hitachi will accept no liability whatsoever for injuries and damages arising from incorrect use or handling that exceeds normal operating limits.

Table of Contents

Disclaimer	1	⑤ Attaching bracket (D).....	11
Table of Contents	1	⑥ Attaching Adjusting block (C)	11
Safety Symbols	1	⑦ Attaching Arm bracket (IN)	12
Overview	2	⑧ Attaching LCD projector	12
Installation Precautions	2	⑨ Connecting cables.....	12
Tools needed for installation	2	Adjustments	13
To the customer	3	⑩ Displaying image for making adjustments	13
To service personnel	3	⑪ Image adjustments	14
Routine Inspections	3	Installing exterior parts	17
Contents of this package	4	⑫ Procedure for installing exterior parts	17
Installation procedure	5	⑬ Connecting cables.....	19
① Removing Arm bracket (IN)	5	⑭ Attaching the cable cover.....	20
② Attaching the base bracket (B) to the wall	6	Adjustment precautions	21
③ Attaching the Arm bracket (OUT)	10	Adjustment specifications	22
④ Securing Arm bracket (OUT) using screws...10		Applicable models	23

Safety Symbols

The following symbols are used in this manual to help you use this product safely and correctly, and to prevent injury to yourself and others or damage to property. Read through the safety instructions below so you can operate the product correctly.

 WARNING	This symbol indicates information that, if ignored, could result in serious personal injury or even death due to incorrect handling.
 CAUTION	This symbol indicates information that, if ignored, could result in personal injury or physical damage due to incorrect handling.



Indicates a prohibited action.

This symbol is accompanied by text indicating an action that must not be taken.



Indicates a mandatory action.

This symbol is accompanied by text indicating an action that must be taken.

Overview

This product is designed to mount a Hitachi LCD projector on a wall.

Installation Precautions

Installation of this product requires special technical skills. Ask your dealer or service center (for details, see the User's Manual supplied with the LCD projector) to handle the installation work.

Be sure to observe the following instructions when installing an LCD projector.





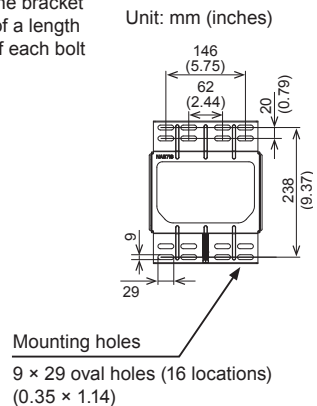

1. Considerable care is required in planning and performing the installation so that it will support the weight of the LCD projector and wall mount unit. Refer to the table listing applicable models.
2. If the temperature inside the LCD projector gets too high, the temperature sensor will activate and turn off the projector to prevent damage. Do the following to avoid an abnormally high temperature.
 - (1) Use the projector within the operating temperature range shown in the User's Manual.
 - (2) Periodically clean the projector's air intake filter. For details on how often and how to clean the filter, see the LCD Projector User's Manual.
 - (3) In a dusty location, the filter will need more frequent cleaning than in (2) above so install the projector in a location where cleaning is easy.
 - (4) Leave 30 cm or more space on the sides of the LCD projector to allow the free flow of air from the exhaust and leave 10 mm or more space at the back of the projector to enable air to enter via the air intake.
 - (5) Do not install the projector in a location exposed to sudden temperature changes, for example near air conditioners, or where the temperature rises above 40°C.
3. Do not install the projector in a smoke-filled or extremely dusty environment as the tar in cigarette smoke will settle on the optics and lower performance.
4. Do not install the projector in a location where the remote control sensor will be exposed to direct sunlight, other strong light sources or inverter fluorescent lamp light at close range to prevent remote control malfunction.

Tools needed for installation









- The wall mount unit must be secured using at least eight M8 anchor bolts. The bracket has 16 oval 9 × 29 mm (0.35 × 1.14 inch) mounting holes. Use anchor bolts of a length that suits the strength and thickness of the wall so that the pullout strength of each bolt meets or exceeds 2,000 N. If required, increase the number of anchor bolts.



 **WARNING**
To the customer

-  ■ Do not attempt to install the projector yourself. Have your dealer or service center handle all installation work. Note that Hitachi will accept no liability whatsoever for accidents or injuries resulting from an incorrect installation or improper use.
-  ■ Make sure that the projector is installed high enough so that there is no risk of people bumping their heads. If a sufficiently high installation cannot be made, be sure to take the necessary precautions when the projector is used.
-  ■ Do not hang on the LCD projector or the arm after installation as this could cause the LCD projector to fall down or bend the arm resulting in injury or damage.
-  ■ Do not install the projector in a location exposed to high humidity, dust or tobacco smoke or in a location exposed to smoke or steam.
-  ■ Do not install the projector in a location exposed to vibrations.
-  ■ After you have finished installation, keep this manual and accessories in a safe place for future reference.
-  ■ Small parts such as screw caps and adjusting knobs could be swallowed by children and pets and should be kept out of their reach. If your child swallows any small parts, consult a doctor immediately.

To service personnel

-  ■ Perform all installation work correctly according to this manual. Make sure that all specified screws and brackets are used in the installation.
-  ■ Considerable care is required in planning and performing the installation so that it will support the weight of the LCD projector and wall mount unit.
-  ■ Never attempt to modify the wall mount unit. (We will not guarantee the strength of a unit that has been modified.)
-  ■ Make sure that all screws are tightened to the proper torque after installation and adjustments. There must be no loose or over tightened screws.
-  ■ Do not use adhesives, lubricants, lubricating oils or other chemicals designed to prevent loosening of fasteners on screws and bolts used to secure the projector ceiling mount. The use of such materials could cause the mount to fail and the projector to fall resulting in damage or injury.
-  ■ Route electric cables as prescribed and take care not to damage them in the installation work.
-  ■ Be sure to read this manual and the User's Manual of the LCD projector prior to installation to ensure that all safety instructions are observed and the projector is correctly installed.
-  ■ Be sure to turn off the LCD projector and disconnect the power plug from the wall outlet before starting installation work.

Routine Inspections

Like the projector, the wall mount unit should be inspected once a year.







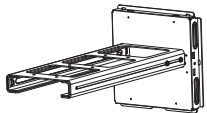
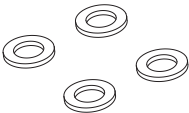
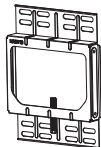
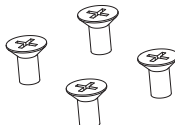
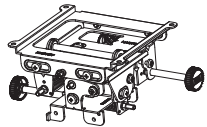

1. Check that the screws in the wall mount unit and adjusted parts are not loose.
2. Check that the wall mount unit, adjusted parts and the set are not scarred or damaged.

HAS-WM03

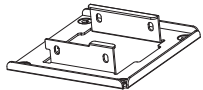
Contents of this package

Check that the items listed in the table below are included in this package. If any are missing, please contact your dealer immediately. (The fasteners (screws, etc.) required for wall mounting are not supplied with the wall mount unit. Select fasteners that suit the structure of the wall to ensure they will properly support the LCD projector and the wall mount unit.)

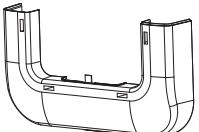
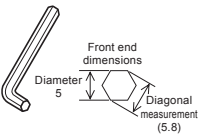
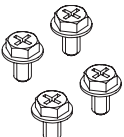
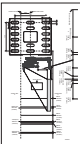
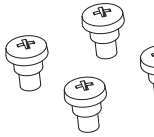
Part names in the figures on the following pages are indicated by the symbols given in the table below.

Symbol	Part name	Quantity	Appearance	Symbol	Part name	Quantity	Appearance
A	Arm assembly	1		I	Washer	4	
B	Base bracket	1		J	M4 dish screw	4	
C	Adjusting block	1		K	M5 screw with lock washer	1	
D	Bracket	1		L	Cable clamp	4	
E	Front cap	1		M	Cable clamp (small)	7	
F	Cable cover	2		N	Allen wrench	1	
G	M4 × 8 hexagon head screws	8		O	Template sheet	1	
H	M5 shoulder screw	4		P	User's Manual (This book)	1	

Installation procedure

- ① **Remove the M4x12 screws from the arm assembly (A) and remove the arm bracket (IN).**

The arm assembly (A) is assembled before shipping. Before attaching the arm assembly to a wall, remove the four M4x12 screws to remove the arm assembly (IN) as shown in the figure below.

ENGLISH

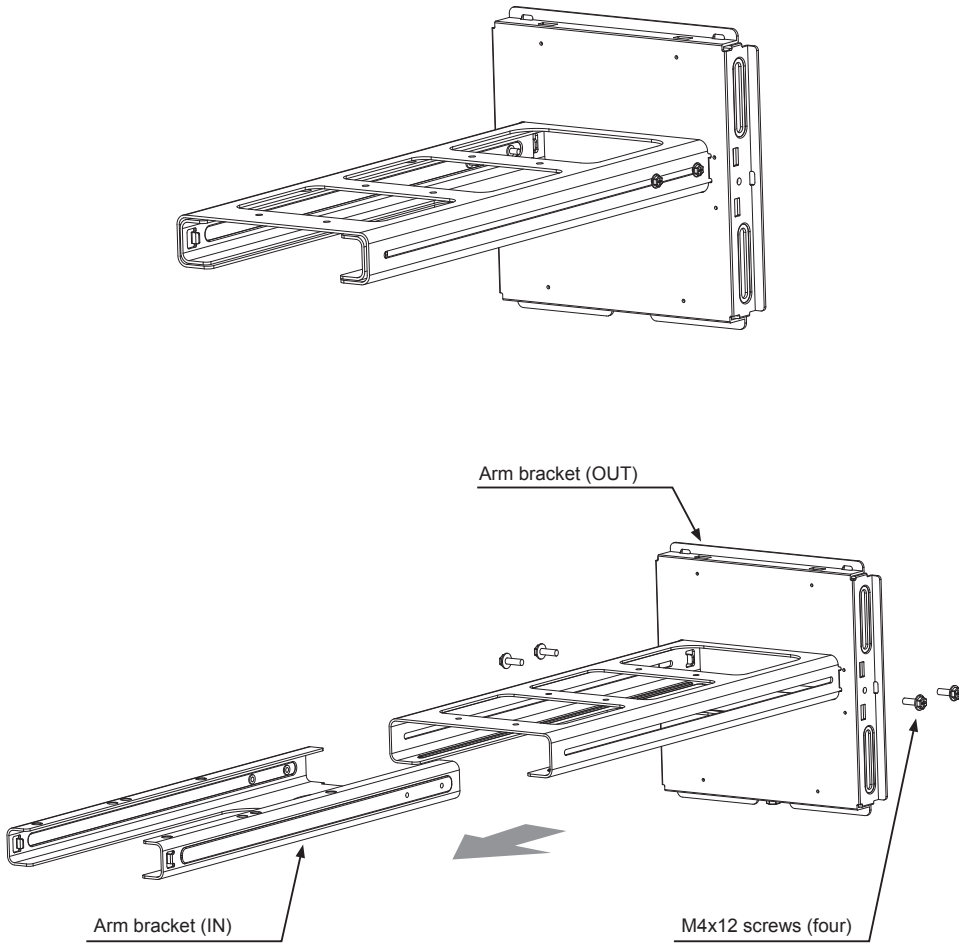

HAS-WM03

② Attach the base bracket (B) to a wall using the anchor bolts (M8).

The holes in the base bracket (B) are oval to permit horizontal adjustment.

For details on the length and number of the anchor bolts (M8) that are required, see "Tools needed for installation" on page 2. Refer to pages 7-8 for instructions on attaching the base bracket.

M8 anchor bolts (8 or more)

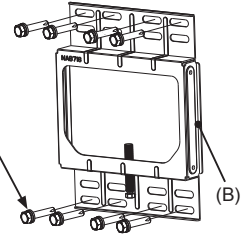

- Use anchor bolts to attach the base bracket (B) to a wall.
- Use M8 anchor bolts.
- Use anchor bolts of a length that suits the material, strength and thickness of the wall so that the pullout strength of each bolt meets or exceeds 2,000 N.
- If the bolts cannot satisfy the required strength specifications, increase the number bolts.

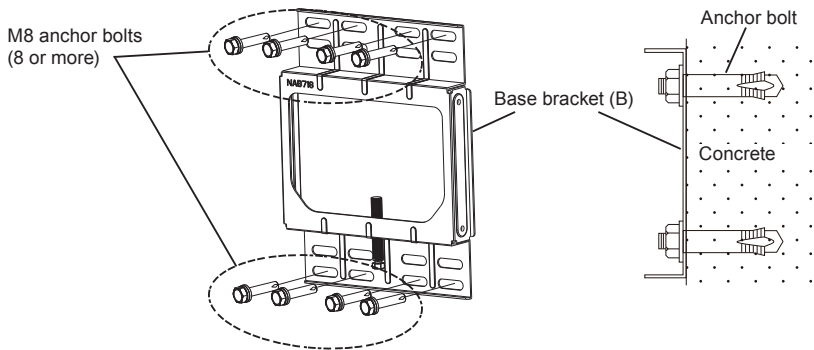

⚠ WARNING

- When attaching the wall mount unit to a wall covered with a layer of plaster or other weak finishing material, make sure the anchor bolts reach into the underlying concrete.

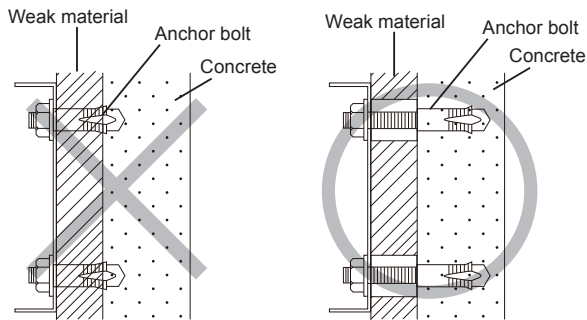

- As shown in the figure, at least eight anchor bolts, two in each corner are required.

HAS-WM03

Base bracket attachment diagram

Note:

The wall hole center is 34.6 mm (1.36 inches) to the right of the screen center.

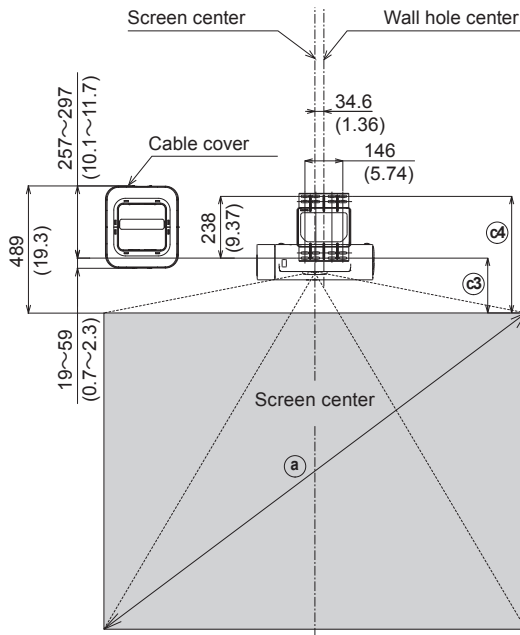

Important dimension

Install 70 mm (2.8 inches) or more away from the top edge of the screen.

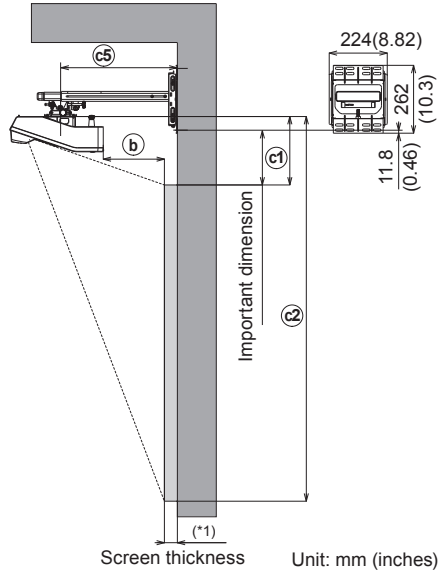

ENGLISH

16:10 screen (Full screen: Reference value for 1,280 × 800 pixel image.)

a	b	c1	c2	c3	c4	c5
Diagonal size (inches)	mm (inches)	mm (inches)	mm (inches)	mm (inches)	mm (inches)	mm (inches)
60	128(5.0)	308(12.1)	1116(43.9)	252(9.9)	490(19.3)	343(13.5)
70	198(7.8)	346(13.6)	1288(50.7)	293(11.5)	531(20.9)	412(16.2)
80	268(10.5)	383(15.1)	1460(57.5)	330(13.0)	568(22.4)	483(19.0)
90	338(13.3)	421(16.6)	1633(64.3)	369(14.5)	607(23.9)	554(21.8)
100	408(16.1)	459(18.1)	1805(71.1)	407(16.0)	645(25.4)	622(24.5)

4:3 screen (Full screen: Reference value for 1,024 × 768 pixel image.)

a	b	c1	c2	c3	c4	c5
Diagonal size (inches)	mm (inches)	mm (inches)	mm (inches)	mm (inches)	mm (inches)	mm (inches)
60	104(4.1)	219(8.6)	1133(44.6)	167(6.6)	405(15.9)	319(12.6)
70	170(6.7)	242(9.5)	1309(51.5)	190(7.5)	428(16.8)	385(15.2)
80	236(9.3)	265(10.4)	1484(58.4)	212(8.3)	450(17.7)	450(17.7)
90	302(11.9)	288(11.3)	1659(65.3)	236(9.3)	474(18.6)	517(20.4)
100	368(14.5)	310(12.2)	1834(72.2)	258(10.2)	496(19.5)	583(23.0)

(*1) For a 50 mm thick screen

Size of images that can be projected with screen sizes of up to 100 inches.

* Use of the supplied template sheet will facilitate positioning of the base bracket.

Note:

Note that projection distance (b) will vary by ±3% depending on what product is used.

HAS-WM03

Template sheet usage

Determining location of wall holes

Place the template sheet (O) where you want to project the image.

- ① Vertical orientation: Align the top of the sheet with the upper edge of the image you want to project.
- ② Horizontal orientation: Align with the screen center.
Note: The base bracket center is 34.6 mm (1.36 inches) to the right of the screen center.

- ③ Make a hole in the wall as indicated by the base bracket figure.

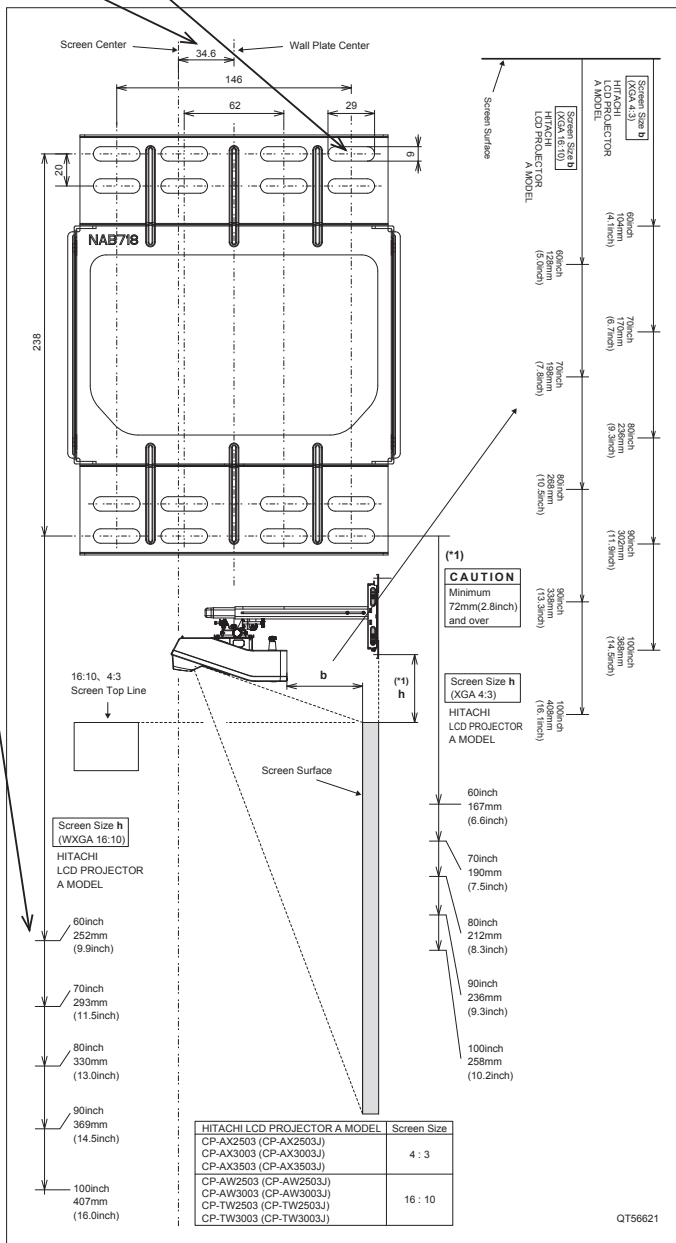

HAS-WM03

Adjusting arm length

Arrows at the right and left sides of the template sheet (O) indicate the distance from the screen surface to the back of the projector.

During rough adjustments of arm length, adjust it according to the dimension of distance (b) from the screen surface to the back of the projector.

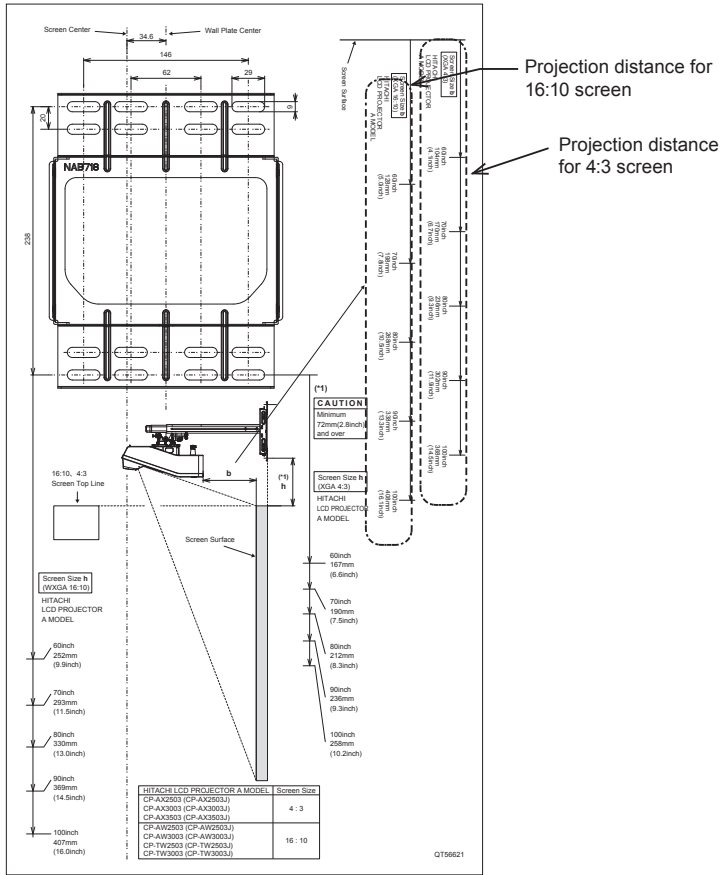

ENGLISH

Example

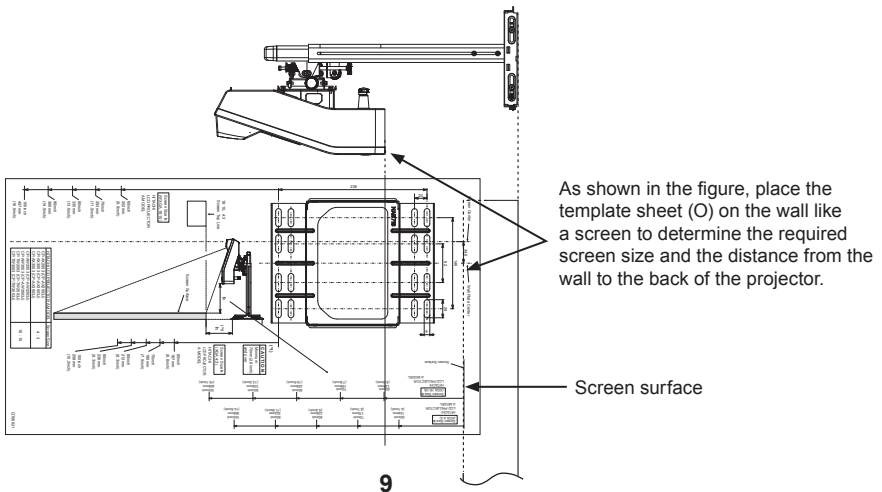

Installing the bracket (continued)

③ Arm bracket (OUT) to the base bracket (B).

Place the arm bracket (OUT) on top of the base bracket (B). Then insert the U-groove at the bottom of the arm bracket (OUT) in the groove of the vertical adjusting nut in the base bracket.

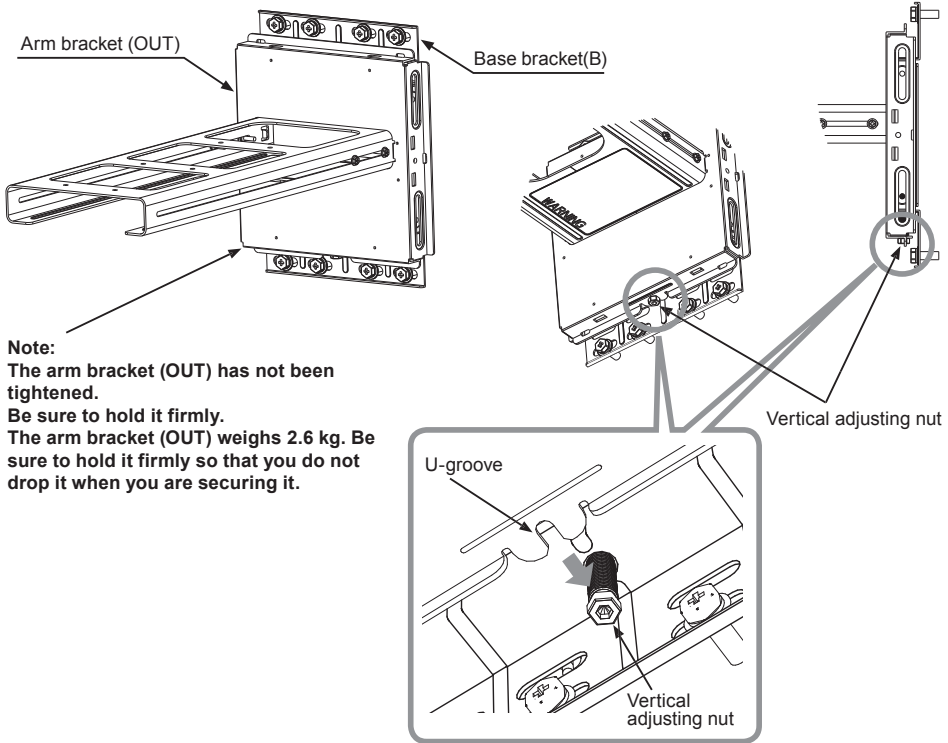

Note:
 The arm bracket (OUT) has not been tightened.
 Be sure to hold it firmly.
 The arm bracket (OUT) weighs 2.6 kg. Be sure to hold it firmly so that you do not drop it when you are securing it.

④ Use four M5 shoulder screws (H), four washers (I) and one M5 screw with lock washer (K) to secure.

Tightening torque: 0.98 N·m (10 kgf·cm)

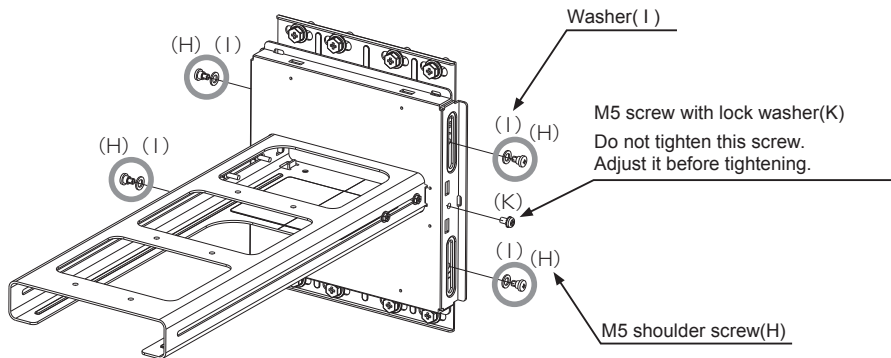

⑤ **Attach the bracket (D) to the LCD projector using four M4 × 8 (G) hexagon head screws.**

Tightening torque: 0.98 N·m (10 kgf·cm)

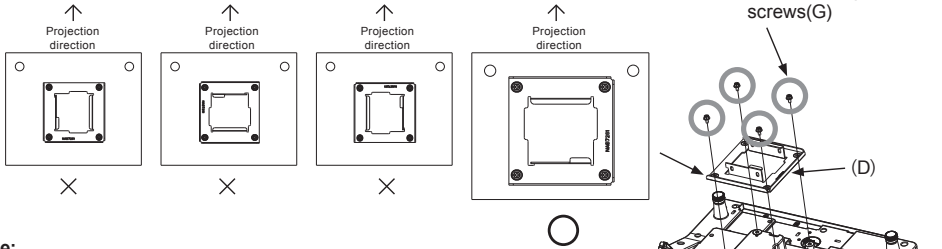

Note:
Make sure that the bracket (D) is correctly oriented.

! WARNING

- Never use screws other than those designated. Failure to heed this warning may cause the projector to fall or other hazard resulting in damage or injury.

Place cushioning material on a workbench. Turn over the projector and place it upside down on the cushioning material on the workbench.

⑥ **Attach the adjusting block (C) to the arm bracket (IN) using four M4 dish screws (K). Adjust according to projection screen size and attach as shown in the figure.**

Tightening torque: 0.98 N·m (10 kgf·cm)

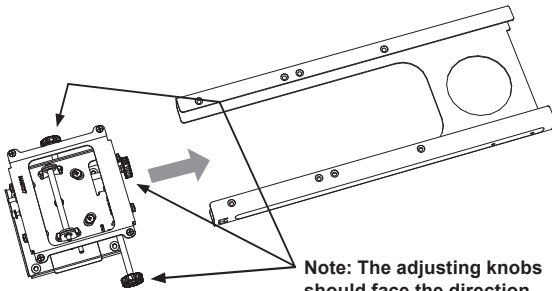

Note: The adjusting knobs should face the direction shown in the figure.

! CAUTION

- Assemble the adjusting block (C) according to projection screen size.

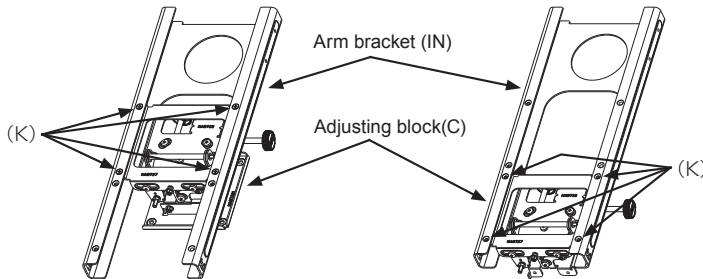

Projection screens smaller than 70 inches

Projection screens 70 inches or larger

⑦ Attach arm bracket (IN) to which the adjustment block (C) has been attached to arm bracket (OUT) using four M4x12 screws.

Tightening torque: 0.98 N·m (10 kgf·cm)

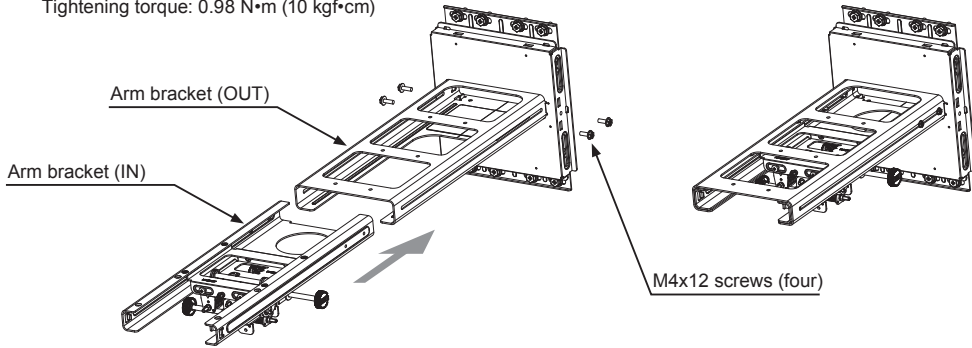

⑧ Attach the LCD projector to which the bracket (D) has been attached to the adjusting block (C).

Tighten the four M4 x 8 round head screws (G).

Tightening torque: 0.98 N·m (10 kgf·cm)

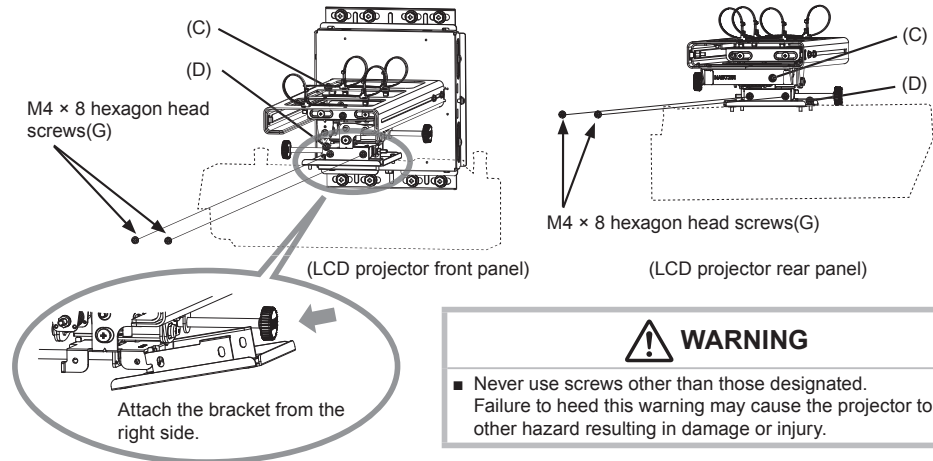

⑨ Attach the four cable clamps (L) and connect the cables to the projector.

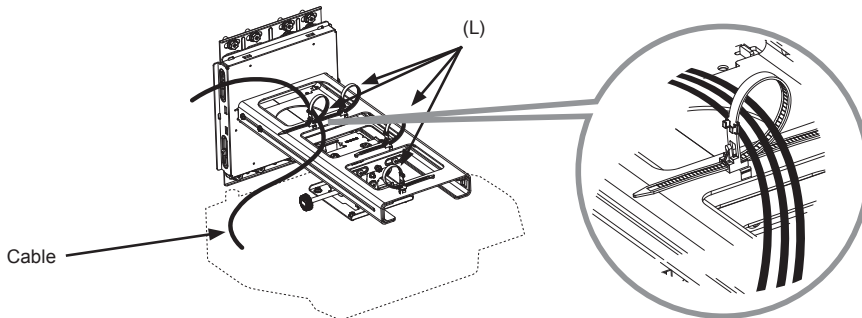

Connect as shown in the above figure.

Adjustments

⑩ Turn the projector on and project an image to make adjustments.

⑩-1. Project an image, adjust the image settings and focus on the LCD projector.

- Adjust the focus.
- Select MIRROR.
- Set the D-ZOOM to its maximum value (full screen).
- Reset PERFECT FIT.
- Set the KEYSTONE and KEYSTONE values to 0.
- * For details, see to the User's Manual for the LCD projector.

⑩-2. Use the remote control to select a screen for making adjustments.

① To simplify adjustments, press the Menu button on the remote control.

The EASY MENU or ADVANCED MENU appears.

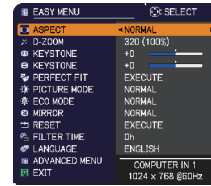
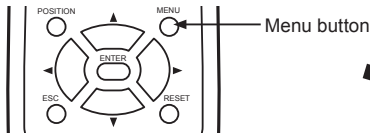

EASY MENU

② Go to step ④ if the ADVANCED MENU appears.

③ If the EASY MENU appears, use the cursor buttons (/) to select the ADVANCED MENU.

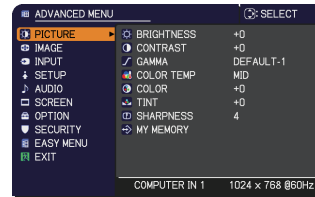
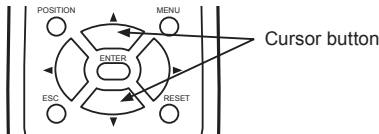

ADVANCED MENU

④ Use the cursor buttons (/) to select SCREEN.

⑤ Use the cursor buttons (/) to select DOT-LINE4 in TEMPLATE.

Then press the ENTER button to display the DOT-LINE4 screen.

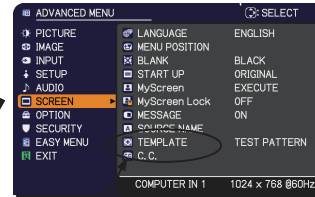
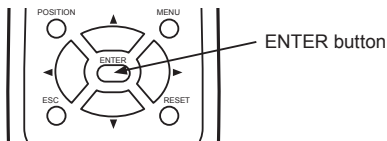

TEMPLATE

⑥ When DOT-LINE4 is displayed on the template, press the INPUT button on the projector or the RESET button on the remote control for three or more consecutive seconds to display the operation guide for the ceiling suspension fittings.

The operation guide will be erased when the button on the projector or remote control is pressed.

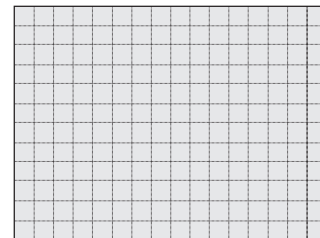
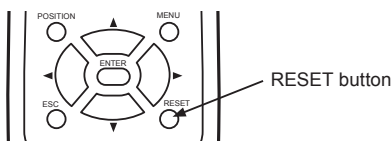

DOT-LINE4 screen

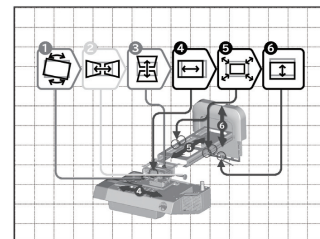

Ceiling Suspension Fittings Operation Guide

HAS-WM03

⑪ Adjust the image.

- ⑪-1. Loosen the securing screws.
(at the eight locations indicated by the arrows in the figure below)

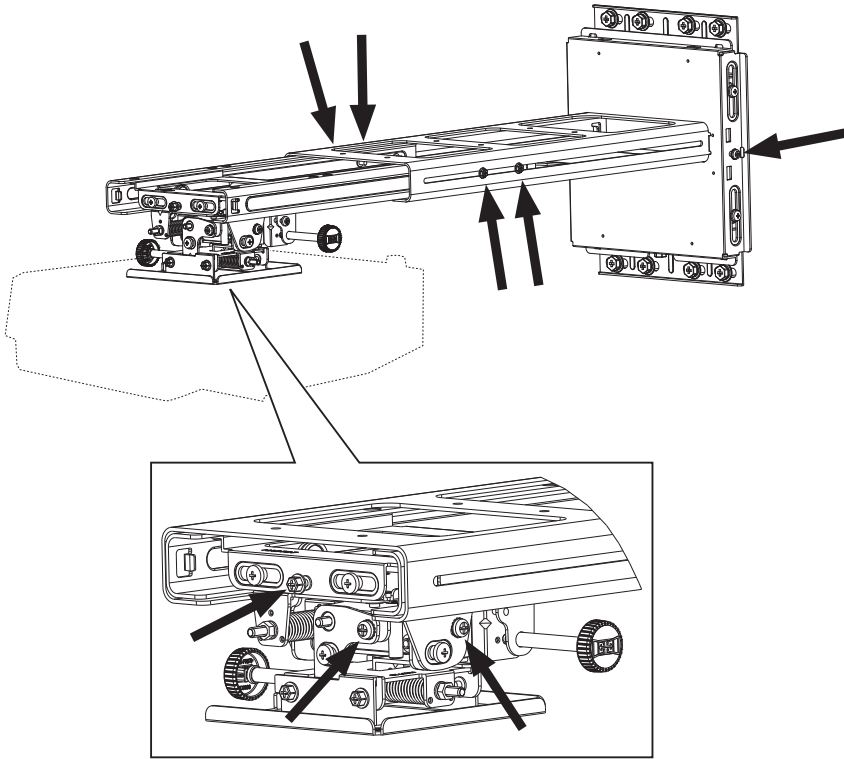

⑪-2. Adjustment of image size.

1. Slide the arm forward and backward to adjust image size.
The scale on the supplied template sheet (O) simplifies adjustment. See page 8 for information on how to use the template sheet.

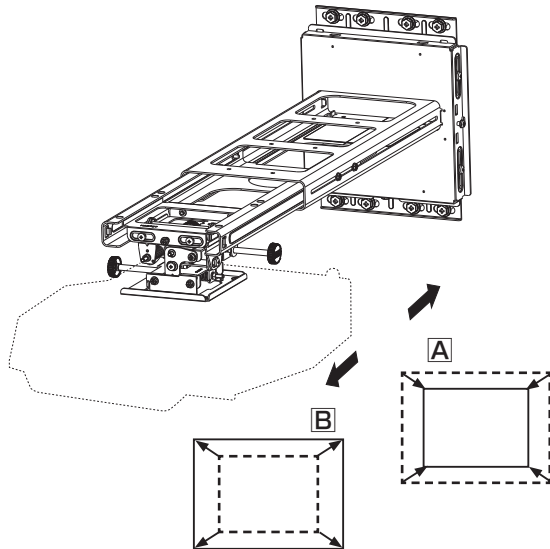

HAS-WM03

ENGLISH

①-3. **Make a rough focus adjustment.**
For details, see the User's Manual for the LCD projector.

①-4. **Make fine adjustments.**
Follow the steps below to turn the adjusting screws and adjusting knobs to adjust the image.

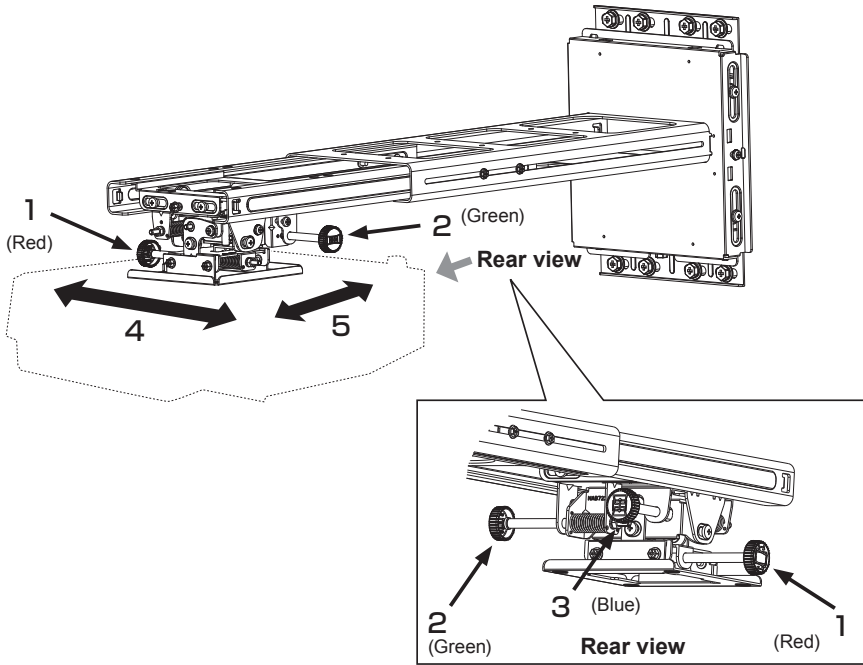

1. Fine adjustment of horizontal position



2. Fine adjustment of horizontal keystone

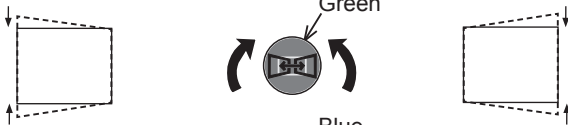

3. Fine adjustment of vertical keystone



4. Fine adjustment of lateral position

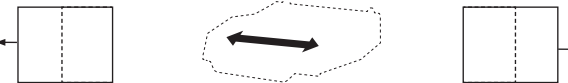

5. Fine adjustment of image size

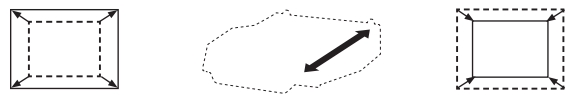

6. **Fine adjustment of focus**
For details, see the User's Manual for the LCD projector.

HAS-WM03

7. Fine adjustment of vertical position

1. Loosen the screw in the middle on the right side.
(Refer to page 14.)

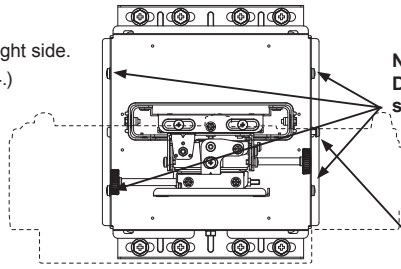

Note:
Do not loosen these Four screws.

2. Turn the height adjusting screw to adjust the height.

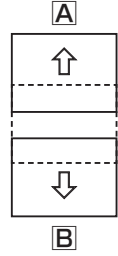
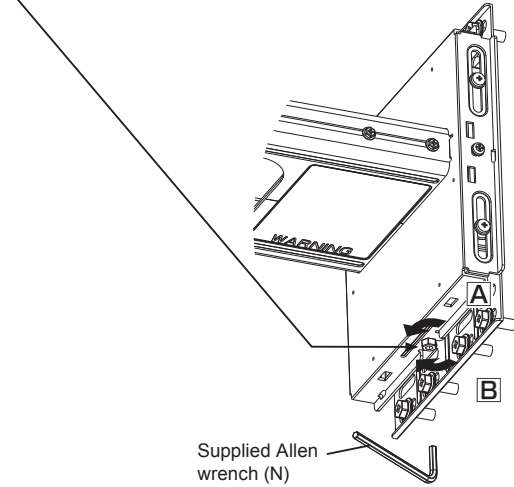

- Repeat steps 1 to 7 to fine adjust the image to the screen.
See page 22 for details on adjustment range.

⑪-5. Retighten the eight previously loosened securing screws.
Be careful not to overly tighten the securing screw.

Installing exterior parts

12 Procedure for installing exterior parts

12-1. The knobs indicated by the arrows can be removed. After you have removed it, put it away in a safe place.

ENGLISH

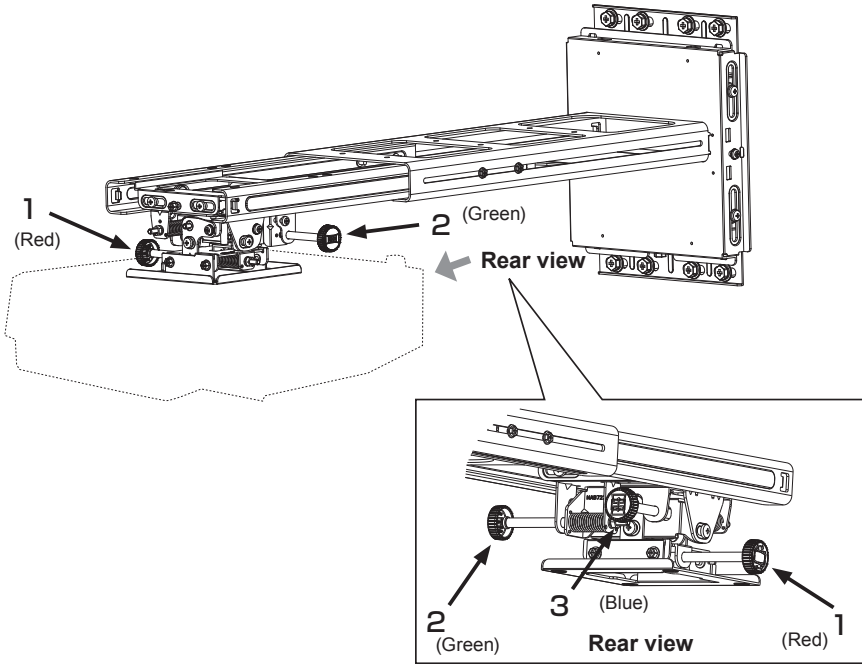

! WARNING



- Adjusting knobs are small parts that could be swallowed by children and pets and should be kept out of their reach. If your child swallows an adjusting knob, consult a doctor immediately. If they are removed, be sure to store them on the projections inside the front cap (C).

HAS-WM03

- ⑫-2. Attach the front cap (E) at the front end of the Arm bracket (IN).
Engage the left and right claws.

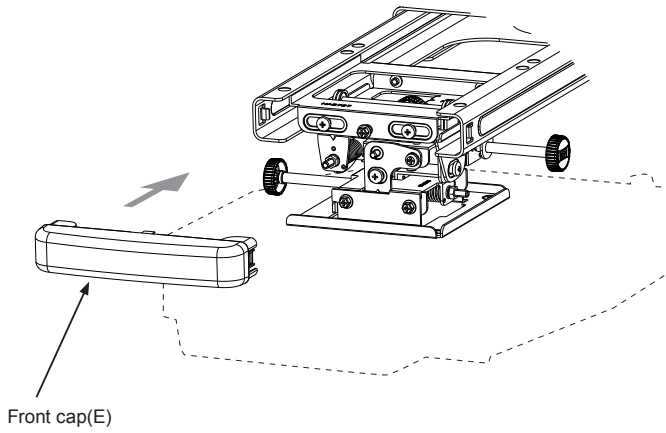

- ⑫-3. Attach the cable cover.

Insert the two tabs (1) and (2) in the cable cover with the two holes (1) and (2) in the LCD projector.
Secure the cable cover screw (3) to the LCD projector (3).

Route the cables through the holes
in the top of the cable cover.

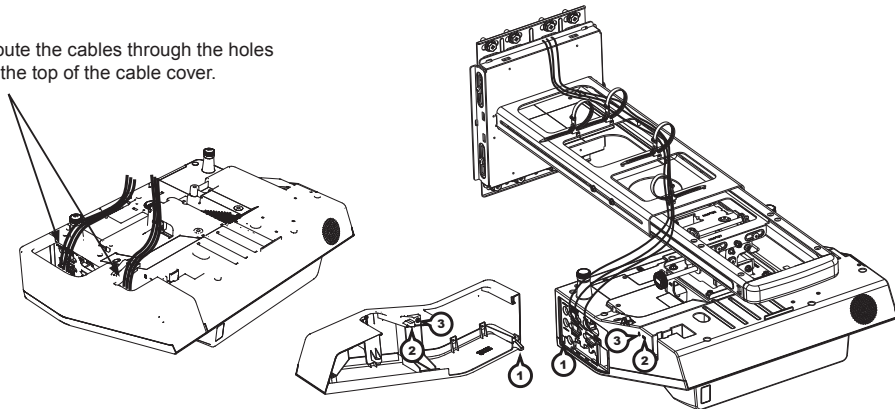

13 Connecting cables

13-1. Use the cable clamp (L) to secure the cables.

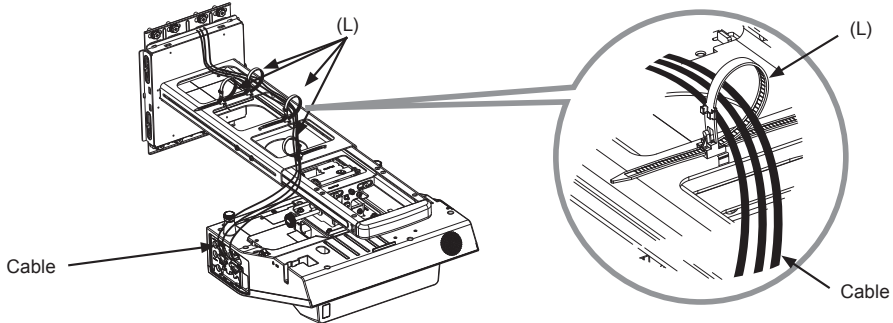

13-2. Leading the cables out from the bottom
Route one cable to the right and the other to the left.

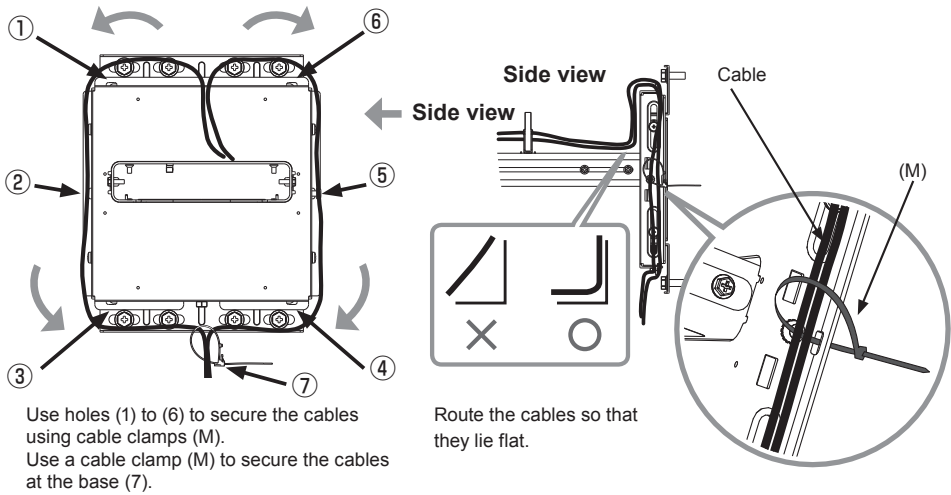

13-3. Leading the cables out from the top

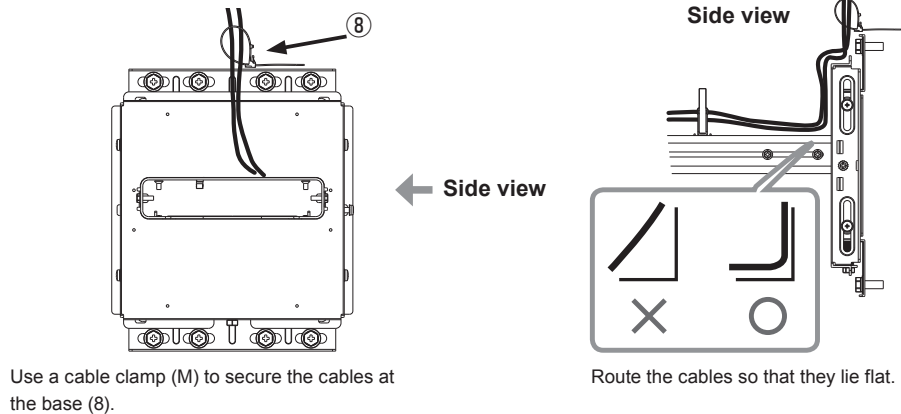

HAS-WM03

⑭ Attaching the cable cover

⑭-1. Attach the cable cover (F) to the arm assembly (A).

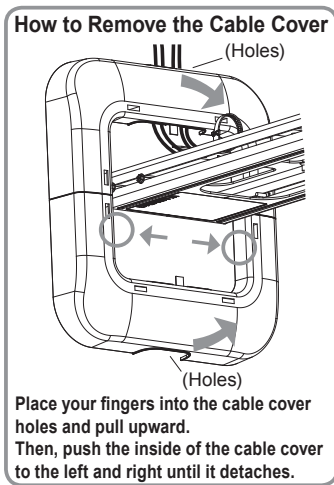
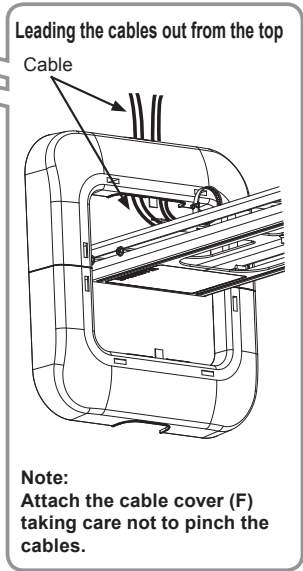
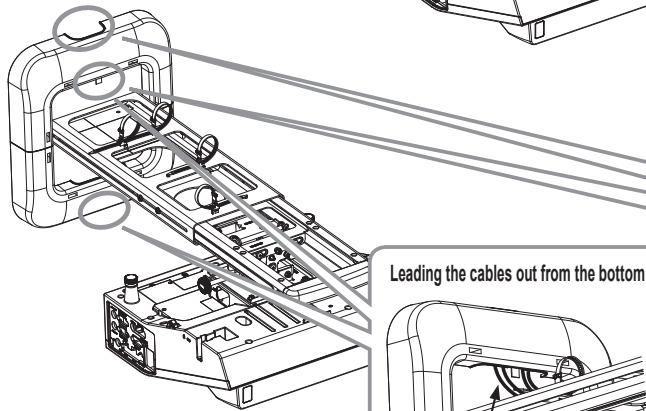
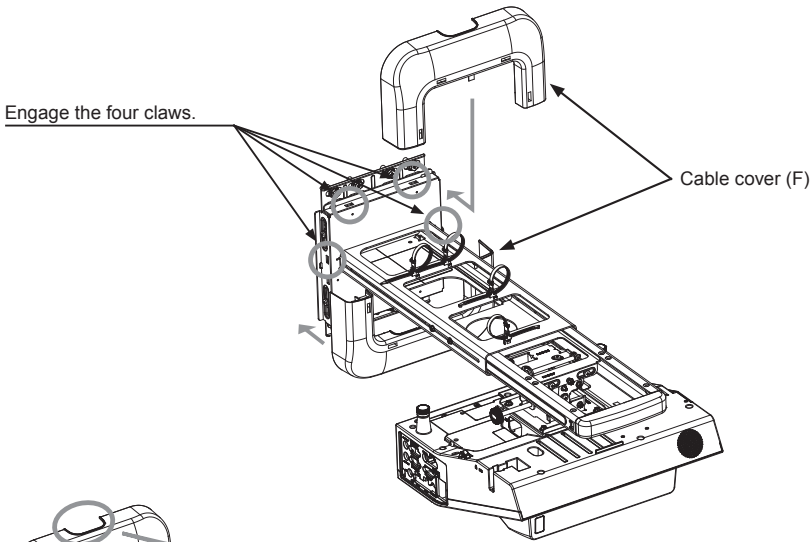

Adjustment precautions

- Roll down screens and other screens that are not perfectly flat tend to substantially distort the projection surface and cannot be used. Use board screens or other flat screens.
 Bead-type screens with a high screen gain are not suitable for this projector. Use of a matte screen with a wide viewing angle and a gain of about 1.0 is recommended.
 Interaction between the screen pattern and LCD pixels may result in interference fringes (moiré). This is not a malfunction. Use a screen that suppresses this phenomenon.
- The size of the image at the top of the screen changes with focus adjustment. Fine-tune screen position and angle after adjusting focus the first time.
- Reset corner fit before starting adjustments.
- Make sure that the digital zoom value is set to the maximum value (full screen) before starting adjustments.
- Make sure that the keystone control is set to 0 (no correction) before starting adjustments.
- It takes about 30 minutes for lamp performance to stabilize and a change in environment may cause subtle changes in projection location and focus. Make proper adjustments to compensate for changes in focus.

Note:

- Changes in temperature, humidity and other ambient environmental factors may result in changes in screen size and location.
 - The minute vibrations and other phenomena that the wall mount unit and the mirror are exposed to will start to cause changes in projection location a week or so after installation.
1. • Set a screen size that is smaller relative to actual screen size to allow for changes after installation.
 • Use the values in the table below to set a vertical and lateral margin.
 • Set a margin for each corner to allow for screen distortion.

(both 4:3 and 16:10 screens)

Screen size Diagonal size (inches)	Vertical margin (mm)	Lateral margin (mm)
60	20	25
80	25	30
100	30	35

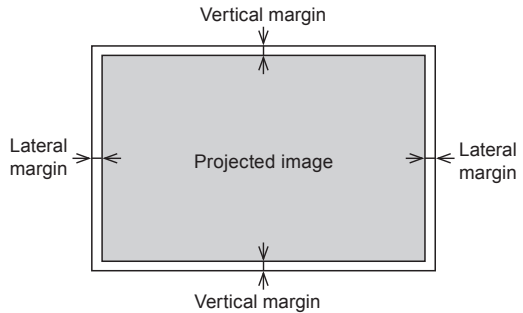

ENGLISH

HAS-WM03

Adjustment specifications

- LCD projector range of motion provided by arm extension/contraction
(See page 14 for adjusting procedure.)

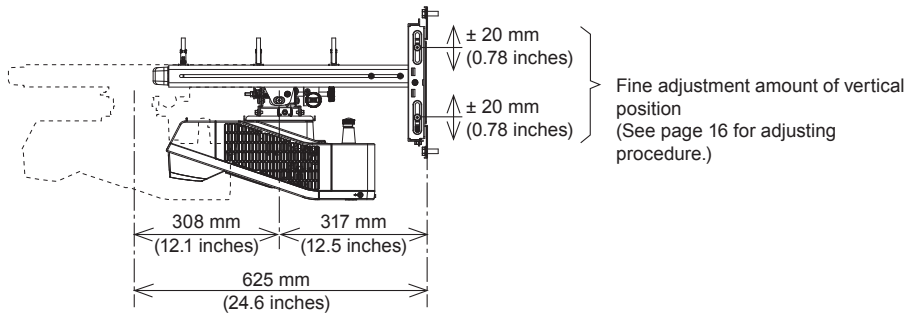

Item	Image movement	Fine adjustment amount (amount of LCD projector movement)	Description of adjustment method
Fine adjustment of horizontal position		$\pm 3^\circ$	page 15
Fine adjustment of horizontal keystone		$\pm 3^\circ$	page 15
Fine adjustment of vertical keystone		$\pm 3^\circ$	page 15
Fine adjustment of lateral position		± 10 mm (0.39 inches)	page 15
Fine adjustment of image size		± 369 mm (12.1 inches)	page 15
Fine adjustment of vertical position		± 30 mm (0.78 inches)	page 16

HAS-WM03

Applicable models

Supported Hitachi LCD projector models

	Model	Screen size	Weight
LCD projector model A	CP-AX2503	4:3	Approx. 4.2kg
	CP-AX3003		
	CP-AX3503		
	CP-AW2503	16:10	
	CP-AW3003		
	CP-TW2503		
CP-TW3003			
Wall mount unit	HAS-WM03		Approx. 5.8kg

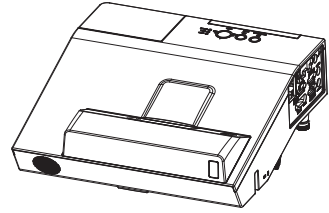

ENGLISH