

Shown: T390110 (16:10 ratio) with optional projector and bracket

## TeamBoard 3 RT

Product Codes  
T380110  
T390110

[www.teamboard.com](http://www.teamboard.com)

Also available:  
Installation solutions  
Touchscreens  
Installation Services  
Professional Development  
Global Online Community

## TeamBoard 3 RT™

TeamBoard is known worldwide for its intuitive usability, robust construction, reliable finger touch interactivity, guaranteed-to-clean surface, and an integrated Action Bar that needs no special pens or parts! Two standard size formats are available: 4:3 or 16:10 widescreen.

### Easy, intuitive finger touch control with the proven RT sensor!

Presenters and learners worldwide have enjoyed TeamBoard's direct touch response for over 15 years. The RT sensor recognizes the direct contact of your finger, a stylus, or any other object, in an easy to use single-user, single-zone interactive space. The RT sensor also offers the integrated Action Bar, for easy one touch commands including page navigation, color, and print.

### Four operating modes

With the RT sensor and its proprietary, (guaranteed-to-clean for 10 years) EVS surface, TeamBoard 3 RT brings you four Easy Does It operating modes: direct touch interactive whiteboard mode; a matte-white, low-glare projection screen; a dry erase whiteboard; and a note-capturing electronic whiteboard.

### New 3 Series Industrial Design

The new 3 Series industrial design brings several new benefits to RT-sensor based TeamBoards. The air gap behind the surface has been reduced, for improved feel, improved tactile response, and improved projected image. The integrated Action Bar now features a lower profile, contributing to the overall increased projected image area of the board, providing more workspace. As well, the new design features a modern look with rounded corners and robust anodized aluminum frame rails.



T380110 (16:10 ratio) with optional integrated projector and bracket.

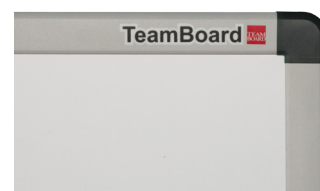

T380110 and T390110 corner detail, dark grey.



205 Westwood Ave, Long Branch, NJ 07740  
Phone: 866-94 BOARDS (26273) / (732)-222-1511  
Fax: (732)-222-7088 | E-mail: [sales@touchboards.com](mailto:sales@touchboards.com)



| Features             |                              | Benefits   |
|----------------------|------------------------------|--|
| RT Sensor Technology | ✓ Resistive Touch technology | <ul style="list-style-type: none"> <li>&gt; Your finger is the mouse – simply touch the board to command your software and operating system.</li> <li>&gt; Easy for learners or presenters of all ages.</li> <li>&gt; Intuitive – directly touch what you wish to control.</li> <li>&gt; No special pens required – nothing to lose or replace. No batteries required.</li> <li>&gt; RT technology provides tactile feedback to your finger touch, with no ‘pre-touch’ activation problems.</li> <li>&gt; Responds quickly and accurately to your touch with a resolution and tracking rate above normal requirements. Where you touch, TeamBoard 3 RT responds accurately.</li> </ul> |

| Features                |   | Benefits  |
|-------------------------|---|---|
| Hardware                | ✓ Widescreen format (T390)  | <ul style="list-style-type: none"> <li>&gt; 16:10 active Projected Image Area (white space) above the toolbar means compatibility with the newest projectors and 20% greater interactive area than traditional interactive whiteboards.</li> <li>&gt; Backwards-compatible with 4:3 projectors: simply calibrate to the center, or to one side.</li> </ul>                          |
|                         | ✓ Action Bar  | > Direct-touch Action Bar is integrated into the RT Sensor, so there are no extra electronics, no cords, and no power required, and no moving parts or pens to fail. Action Bar works in Interactive Whiteboard Mode as well as in Electronic Whiteboard Mode (for dry erase whiteboard capture).   |
|                         | ✓ Egan Versa Presentation Surface (EVS)   | > An Egan TeamBoard exclusive, EVS is an enhanced presentation surface. Guaranteed-to-clean dry erase for daily use, and a low-gloss, 160° viewing angle projection surface.  |
|                         | ✓ High Quality Egan® Board foundation   | > Steel-backed, recycled aluminum core frame with recycled kraft honeycomb core construction provides excellent dimensional stability for even the toughest environments. The lightest, strongest, most environmentally friendly TeamBoard ever. The extruded recycled aluminum external frame also means high aesthetic appeal and robust functionality in almost any environment. |
|                         | ✓ Replaceable Controller  | > Without the use of tools, the controller can be easily swapped out, for no-hassle maintenance. The controller can also be flashed for minor upgrades.   |
|                         | ✓ Minimal Air Gap   | > Air gap is minimized, resulting in improved projector image and touch accuracy.   |
|                         | ✓ Nominal Surface Tension   | > Finger fatigue is reduced, and surface smoothness and board life are optimized.   |
|                         | ✓ Dynamic Surface Tension   | > The RT Sensor is installed with a dynamic tension frame around its perimeter, so low tension and even tension are assured even in changing room conditions (e.g. heat, humidity). This permits a smooth surface for optimal projection and tactile response.  |
|                         | ✓ Color   | > EganMetallic frame color, with rounded gray corners.  |
| ✓ Open License Hardware | > TeamBoard permits hardware to be used in conjunction with any software, including any brand of interactive whiteboard software. |   |

| Features |   | Benefits  |
|----------|---|---|
| Software | ✓ Drivers   | > Downloadable drivers for Windows, Mac OS X, and Linux. Upgrades, as released, are free forever.   |
|          | ✓ Canvas-style Interactive software included                                | > TeamBoard Draw interactive whiteboard software enables canvas-style planning and interactive delivery of presentations and lesson plans. Also great for annotation and note capture.  |
|          | ✓ TeamBoard Draw™ Site License included                                     | > With the purchase of any TeamBoard hardware that includes TeamBoard Draw, the EULA grants you a site license for the software, so teachers and presenters can install unlimited copies on their work laptops for preparation of files at home.                          |
|          | ✓ Palette-style Interactive Tools US & Canada: included Elsewhere: optional | > Includes a 5-user license for TeamBoard OEM WizTeach Tools, a floating ‘always on’ tool palette that makes any content interactive. Any lesson comes alive, on the fly! Download a demo at <a href="http://www.teamboard.com/wizteach">www.teamboard.com/wizteach</a> . |
|          | ✓ TeamBoard OEM WizTeach Site License options                               | > Fifteen unused 5-user licenses may be exchanged free of charge for a Site License good for one school building. Other Site licensing options are available to suit your organization’s needs.   |
|          | ✓ Open EULA   | > TeamBoard Draw has an ‘open’ End User License Agreement, which permits use of TeamBoard Draw on any brand of hardware. TeamBoard OEM WizTeach may also be installed on any hardware. Policies of other hardware companies may restrict your rights.                     |



| Features             |                            | Benefits  |
|----------------------|----------------------------|---|
| Support for Teachers | ✓ Meets global standards   | > TeamBoard Draw meets the industry standard *.iwb common file format for easy interchange of your lesson plans between hardware platforms.   |
|                      | ✓ Global Online Community  | > Teachers get free access to TeamBoard Apeeron, the new global community where teachers can exchange content files, share ideas, access product information, and log support cases. <a href="http://www.apeeron.teamboard.com">www.apeeron.teamboard.com</a> . |
|                      | ✓ Lesson Plan Services     | > TeamBoard provides access to fee-based lesson plan services for file conversion and bespoke lesson plan development – by teachers, for teachers. Inquire today.   |
|                      | ✓ Professional Development | > TeamBoard Academy provides a range of professional development courses – on site, by teachers, for teachers. See <a href="http://www.teamboard.com">www.teamboard.com</a> .   |

| Features                   |                               | Benefits  |
|----------------------------|-------------------------------|---|
| Easy-Does It® Installation | ✓ Wallmount Ready             | > Ships with a fixed-position wallmount bracket for easy installation. Additional wallmount brackets are available for economical multiple heights and locations.   |
|                            | ✓ Integrated Security Bracket | > Low profile security brackets are integrated into the frame design, providing increased wall mount stability with a low visual profile.   |
|                            | ✓ TeamBoard Mount Compliant   | > Bolt pattern in rear of board is backwards-compatible with installation solutions designed for the TeamBoard RT product line. Some mounts may require use of adapter for optimal fit. See the entire range of free-standing, mobile, and wallmount installation solutions at <a href="http://www.teamboard.com">www.teamboard.com</a> . |
|                            | ✓ VESA Mount Compliant        | > Secondary bolt pattern in rear of board is industry-standard VESA 800mm x 800mm and 600mm x 600mm compliant, opening up a wide range of third-party installation and mount options.   |

## Design Intent

Direct finger touch response means you directly touch what you wish to control, and offers our distinct simple-to-use operating modes, so you can teach or present *your way*.

| Operating Modes          |              |              |  |
|--------------------------|--------------|--------------|--|
| TeamBoard Operating Mode | Computer     | Projector    | Capabilities   |
| Interactive Whiteboard   | ✓            | ✓            | Full, finger touch interactive whiteboard environment. Run presentations, building them on the go.   |
| Electronic Whiteboard    | ✓            | Not Required | Use the board as a dry erase surface, capturing your notes and drawings electronically on your computer for retention and distribution as jpeg, pdf, or other formats.                 |
| Whiteboard               | Not Required | Not Required | Your TeamBoard is also a regular use dry erase whiteboard, because the EVS surface is guaranteed-to-clean. You don't lose valuable dry erase real estate when you install a TeamBoard. |
| Projection Screen        | Not Required | ✓            | Your TeamBoard is a projection screen thanks to the low-gloss EVS surface.   |

| Operating Specifications  |   |
|---|---|
| <b>Resolution</b>   | 4096 x 4096   |
| <b>Tracking Speed</b>   | 200 inches/second approximates 'real time'  |
| <b>Aspect Ratio</b>   | T390 model is 16:10 aspect ratio in the active projected image area<br>T380 model is 4:3 aspect ratio in the active projected image area  |
| <b>Action Bar</b>   | Direct touch, with commands for print, new page, copy page, and page navigation.  |
| <b>Screen Surface</b>   | Strong, durable, hard-coat EVS; moisture, dust and sunlight operable. Suitable for dry erase and projection.  |
| <b>Certifications</b>   | CE, FCC, TUV, and RoHS compliant.<br>The management systems governing the design and manufacture of this product are ISO9001:2008 certified.  |
| <b>Environmental Compliance</b>   | TeamBoard 3 is GREENGUARD™ Children & Schools compliant, for improved Indoor Air Quality and LEED credit support.<br>TeamBoard 3 is built to last: Aluminum is 100% recyclable and recycled. Recycled honeycomb core. Durable frame. Guaranteed-to-clean surface; even permanent marker, if used accidentally, is easy to remove.<br>The management systems governing the design and manufacture of this product are ISO14001:2004 certified. |
|  <b>GREENGUARD</b><br>Children & Schools<br>Indoor Air Quality Certified |   |
| <b>Computer Compatibility</b>   | Windows Vista or later, Mac OS X, and Linux compatible. Software requires 500MB RAM, 300 MB hard drive space, and 500 MHz CPU or better.<br>Driverless, TeamBoard 3 RT will run in single user, binary touch mode with Windows Vista or later.  |
| <b>Software</b>   | Includes TeamBoard Suite with TeamBoard Draw. Upgrades are free, unlimited, and downloadable. In the United States and Canada, includes WizTeach single 5-user license.   |
| <b>Connection</b>   | 1 USB port required on PC; connection is optimized with USB 2.0 or better. The shielded RJ45 cable connects via adapter (included).   |
| <b>Power Requirements</b>   | No external power requirements; power is drawn by USB computer connection   |
| <b>Power Consumption</b>  | DC+5V max 300mA (1.5 watts)   |
| <b>Data Transfer Rate</b>   | 12 Mbps   |
| <b>Temperature Range</b>  | Operating: -40°F – 94°F (-40°C to 35°C)<br>Storage: -40°F – 120°F (-40°C to 50°C)<br>Change tolerance: slope less than 55°F/hour (25°C/hr)  |
| <b>Humidity Tolerance</b>   | Operating: 0%-80% non-condensing<br>Storage: 0%-95% non-condensing  |
| <b>Accessories included</b>   | Dry erase markers (ACMI certified non-toxic), EganCloth   |
| <b>Warranty (US &amp; Canada)</b>   | TeamBoard 3 RT features a 5-year hardware warranty (2 years, expanding to 5 free of charge with registration by the end user with Egan TeamBoard Inc., within 90 days of purchase.) and a 10-year surface warranty. An extended warranty may be available for purchase, contact TeamBoard for information. Warranty outside the US & Canada may vary; please enquire.   |

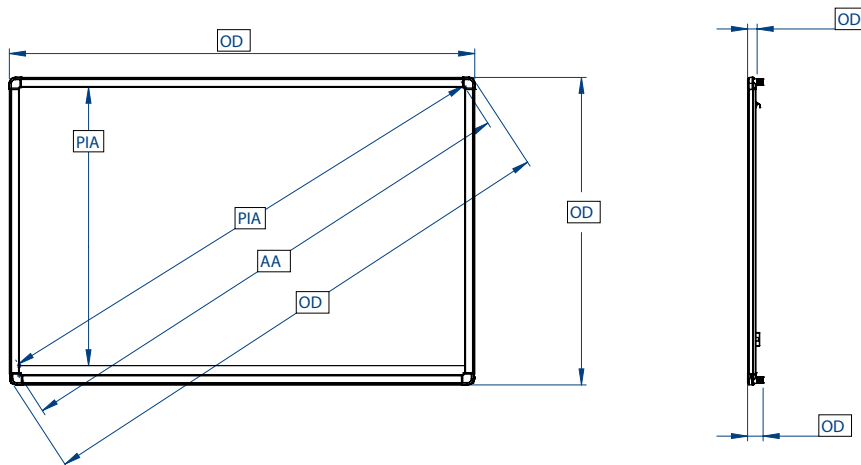

| Dimensions   |                  | T380110 |       | T390110 |       |
|--|------------------|---------|-------|---------|-------|
| <b>Interactive Whiteboard</b><br>Outer Dimensions (OD) | Diagonal:        | 80"     | 2.04m | 90"     | 2.29m |
|  | Width:           | 63 ¾"   | 1.6m  | 75 ¾"   | 1.92m |
|  | Height:          | 50"     | 1.27m | 50"     | 1.27m |
|  | Board Thickness: | 1.5"    | 40mm  | 1.5"    | 40mm  |
|  | Overall Depth:   | 2.5"    | 65mm  | 2.5"    | 65mm  |
| <b>Active Area overall</b><br>(AA)                     | Diagonal:        | 76 ½"   | 1.94m | 86 ¼"   | 2.19m |
|  | Width:           | 60"     | 1.53m | 72 ½"   | 1.84m |
|  | Height:          | 46 ¾"   | 1.2m  | 46 ¾"   | 1.2m  |
| <b>Active Projected Image Area</b><br>(PIA)            | Diagonal:        | 75 ½"   | 1.92m | 85 ½"   | 2.17m |
|  | Width:           | 60"     | 1.53m | 72 ½"   | 1.84m |
|  | Height:          | 45 ½"   | 1.15m | 45 ½"   | 1.15m |
| <b>Pen Tray (sold separately)</b>                      | Width:           | 36"     | 914mm | 36"     | 914mm |
|  | Height:          | 1 7/8"  | 48mm  | 1 7/8"  | 48mm  |
|  | Depth:           | 1 7/8"  | 48mm  | 1 7/8"  | 48mm  |

## What's in the box...

- Your new TeamBoard
- Mounting bracket
- Installation Instructions
- USB/RJ Connector and cables
- Download instructions for your software and drivers.
- Stylus

## Shipping Details

|                        |                     |                     |                    |                     |                    |
|------------------------|---------------------|---------------------|--------------------|---------------------|--------------------|
| <b>Shipping Carton</b> | Width:              | 66 ¼"               | 1.7m               | 79"                 | 2m                 |
|                        | Height:             | 53 ½"               | 1.36m              | 53 ½"               | 1.36m              |
|                        | Depth:              | 3.5"                | 90mm               | 3.5"                | 90mm               |
|                        | Volume:             | 7.2 ft <sup>3</sup> | 0.21m <sup>3</sup> | 8.6 ft <sup>3</sup> | 0.25m <sup>3</sup> |
| <b>Pallet Quantity</b> | Units:              | 13                  |                    | 13                  |                    |
| <b>Board Only</b>      | Net Weight:         | 58lbs               | 26.5kg             | 70lbs               | 32kg               |
| <b>Shipping Weight</b> | Gross Weight:       | 84lbs               | 38kg               | 97lbs               | 44kg               |
| <b>Documentation</b>   | Harmonization Code: | 8473 30 5000        |                    |                     |                    |
|                        | Country of Origin:  | Canada              |                    |                     |                    |

Note: Measurements are nominal and subject to change without notice.

**205 Westwood Ave, Long Branch, NJ 07740**  
**Phone: 866-94 BOARDS (26273) / (732)-222-1511**  
**Fax: (732)-222-7088 | E-mail: sales@touchboards.com**

Designed and manufactured in North America by **Egan TeamBoard Inc.**, leaders in interactive whiteboard solutions since 1994. TeamBoard is part of the Egan Visual family, designers and manufacturers of visual communication products for over 40 years. You can count on TeamBoard products to be well-designed and well-built for years of hassle-free enjoyment. **Environmentally responsible design, quality, value and timeliness.** Egan TeamBoard Inc. has been certified by UL™ to have established, documented, implemented and continuously maintains a Quality Management System and Environmental Management System, as a registrant of the ISO 9001:2008 and ISO 14001:2004 standards.

**Learn or Buy**  
 teamboard.com  
 sales@teamboard.com  
 +1-905-851-2826

**Connect & Share**  
 apeeron.teamboard.com  
 facebook.com/teamboard  
 twitter.com/teamboard

**Support**  
 apeeron.teamboard.com  
 support@teamboard.com

