

Technical Specifications

| | |
|-------|---|
| 38964 | 42" Flex Insight XMS dual monitor workstation w/ lock |
| 38962 | 42" Flex Insight XMS dual monitor workstation |

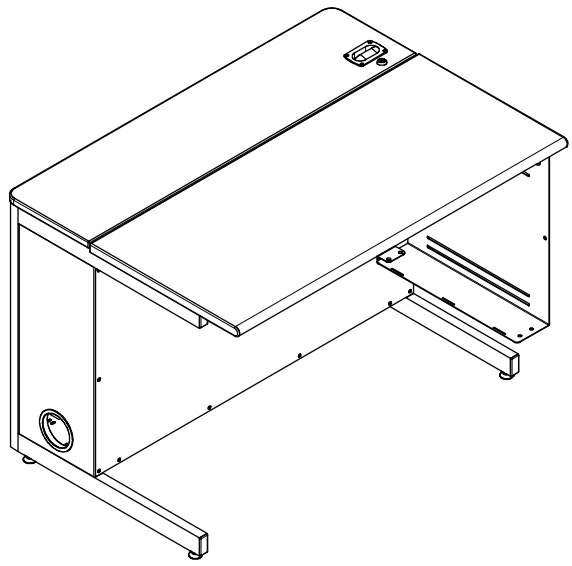

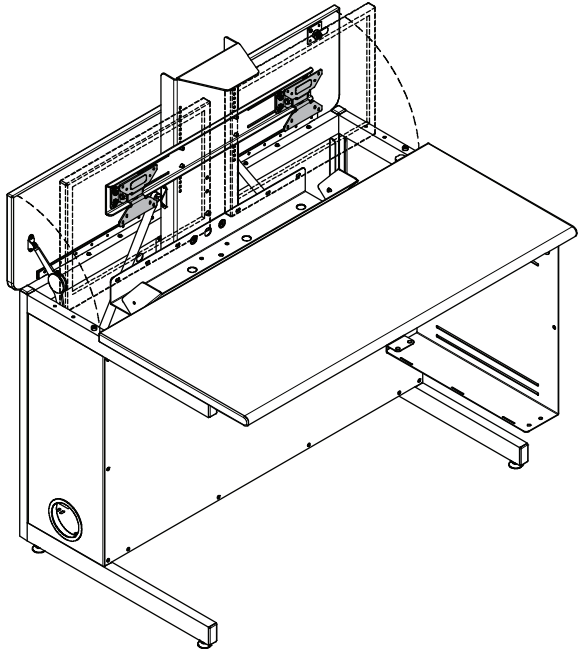



205 Westwood Ave, Long Branch, NJ 07740
 Phone: 866-94 BOARDS (26273) / (732)-222-1511
 Fax: (732)-222-7088 | E-mail: sales@touchboards.com

Page 5 Options & Accessories

Color Options

Standard laminate / color combinations

- Wild Cherry / Black (CHB) 
- Indigo Organix / Black (IB) 
- Fusion Maple / Black (FMB) 
- White Fiesta / Cool White (WFCW) 
- Indigo Organix / Cool White (ICW) 

Standard color combination refers to the quickest deliverable product color combination. Custom laminates and color combinations are available-additional lead-times and up-charges may apply. Call 1-800-235-1262 for further information.

The graphics and capabilities of dual monitors are amazing. However, such technology takes up valuable desk space and makes communicating with students difficult. Wouldn't it be wonderful if you could make the large screens disappear when you really need to get the classroom's attention? With Spectrum's Flex Insight Extreme Monitor System Desks, you can change from computer instruction to traditional instruction in seconds. With classroom space at a premium, doesn't it make sense to get the most out of technology by being able to transform a computer lab into a study or lecture room? Now it can be done with Spectrum Flex Insight Extreme Monitor System Desks.

Features and Benefits

- Desk allows any classroom to be reconfigured from a lecture hall to a computer training lab in seconds
- Manually-actuated monitor column with pneumatic cylinder spring-assist allows the monitors, keyboard, and mouse to be moved up when needed, and retracted with the lid closed to convert the desk to a conventional student desk
- Easy lift mechanism for two monitors (up to 32 lbs total) with keyboard and mouse
- Large storage compartment for 2 monitors up to 19" in 16:9 aspect ratio
- Vertical lift of monitors to eye level above desk provides ergonomic viewing angle to prevent user fatigue
- Available in locking or non-locking monitor compartment versions
- Proven triple ball bearing rail lift column design provides smooth operation, reliability, and long life
- Built in lift/lower handle is used to lift and lower so monitors are not damaged
- Monitor compartment lid protects and secures dual monitors, keyboard, mouse, and provides 19" of uninterrupted workspace in front of lid
- Monitor compartment is designed so that monitors stay inside compartment width when raising and lowering to prevent damage from occurring
- Friction dampener on monitor lid provides support and dampening, and slows the lowering of the lid, keeping hands and fingers safe
- Swivel VESA mount brackets works with standard 75mm and 100mm VESA monitor mounts (4mm mounting screws not included)
- Cord channel conveniently keeps computer wires and cables out of the way, and is wide enough to accept most power strips
- Large, 4" side-panel cord management grommets create a continuous cord channel when desks are placed side-by-side
- Adjustable CPU sling with heavy-duty adjustable straps for CPU storage (8-1/2"W x 18"D x 20"H)
- Superior cord management and wire loom protects wires and cables between monitor and power strip
- Removable rear security panel provides security and easy-access to cables and equipment (secured with 4mm JC bolts and hex wrench)
- Scratch and impact-resistant, high-pressure laminate worksurfaces (1¹/₁₆" worksurface, 1³/₁₆" monitor lid)
- Ergonomic, bullnose front edge is easy on wrists
- Quick-connect unit-to-unit brackets allow desks to be connected together
- All wires are protected from student-access by an enclosed metal compartment to prevent tampering-insuring valuable classroom instruction time
- Warranted to be free of all defects in materials and workmanship with a 10-year warranty (1-year on pneumatic lift cylinder)

Construction

- The worksurface is constructed from 1¹/₁₆" thick NAUF (No Added Urea Formaldehyde) composite board with .030 high-pressure laminate, and a balancing phenolic backer on the bottom side. The left and right edges are finished with 3mm vinyl edge-band.
- The monitor compartment lid worksurface is constructed from 3³/₄" thick industrial-grade composite board with .030 high-pressure laminate on both sides-all edges are finished with 3mm vinyl edge-band
- Welded, 16-gauge 1" x 2" rectangular steel tube legs
- Upper leg panel, 14 gauge
- All metal components are finished with a scratch-resistant powder coat epoxy paint
- Each Flex Insight XMS Desk is factory-assembled, packaged and shipped on its own skid

Specifications

| | |
|--|---|
| Lift mechanism | manually-actuated with pneumatic spring-assist |
| Lift capacity | 14-32 lbs (factory preset) |
| Maximum monitor size | 19" with 16:9 aspect ratio (qty: 2) |
| Lower wiring tray for power cords and power strips | 38"W x 9 ³ / ₈ "D x 3 ⁷ / ₈ "H |
| Lower wiring tray power cutouts | 5"W x 3 ¹ / ₈ "D (2 per tray) |
| CPU sling capacity | 18"D x 18"H |
| ADA-compliance* | knee clearances: 38 ⁵ / ₈ "W x 19"D x 28"H (1 person per desk) <small>*Minimum ADA guidelines for knee clearances are 30"W x 19"D x 27"H</small> |
| Unit weight (nominal) | 135 lbs |
| Shipping weight (nominal) | 172 lbs |
| Meets or exceeds all ANSI-BIFMA test standards | |

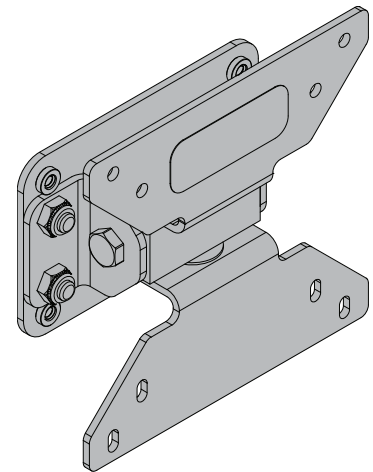

Standard Swivel VESA Monitor Mount w/ internal travel stops
(two included with mounting screws)

provides 4-direction tilt
(4° left & right, 16° up, and 6° down)
Works with 75mm and 100mm VESA monitor mounts
(4mm monitor mounting screws not included)

Note: Specific monitor size, shape, & mounting location will determine exact angles of tilt.

Includes:

- (2) Swivel VESA monitor mounts with mounting screws
- Deluxe internal heavy-duty metal keyboard / mouse tray
- 4mm hex wrench for instructor-access
- Two keys are included with each lock (locking desks only)
- Wire loom for keyboard, mouse, and monitor cables protect cables from pinching
- Rubber keyboard tray pads (protect keyboard)
- One unit-to-unit bracket (desks must be same height to connect)

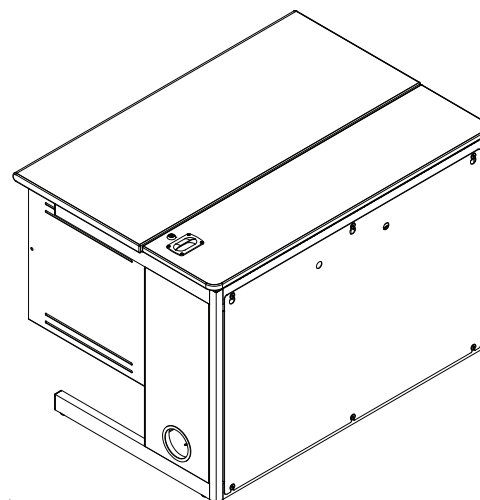
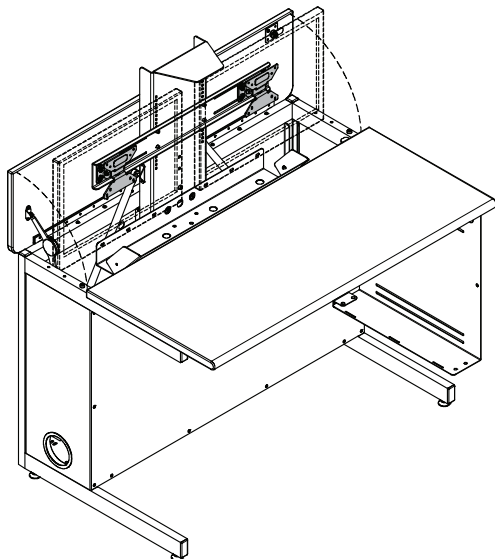
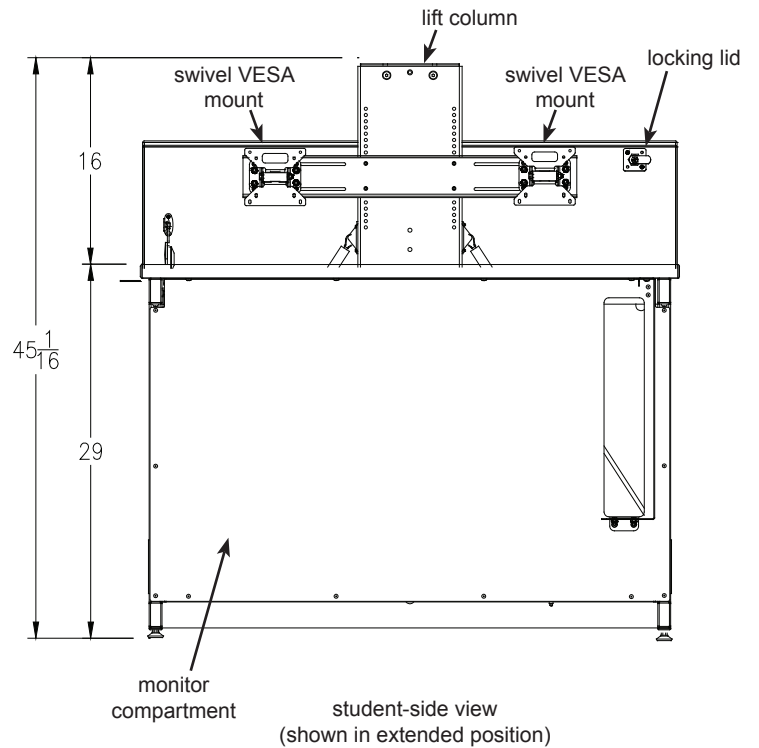
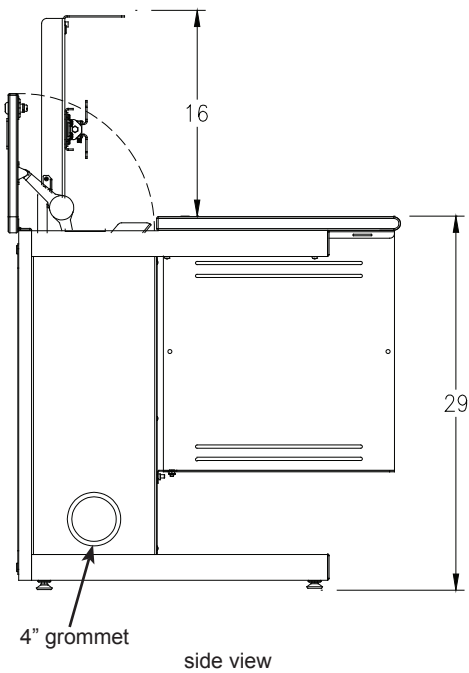
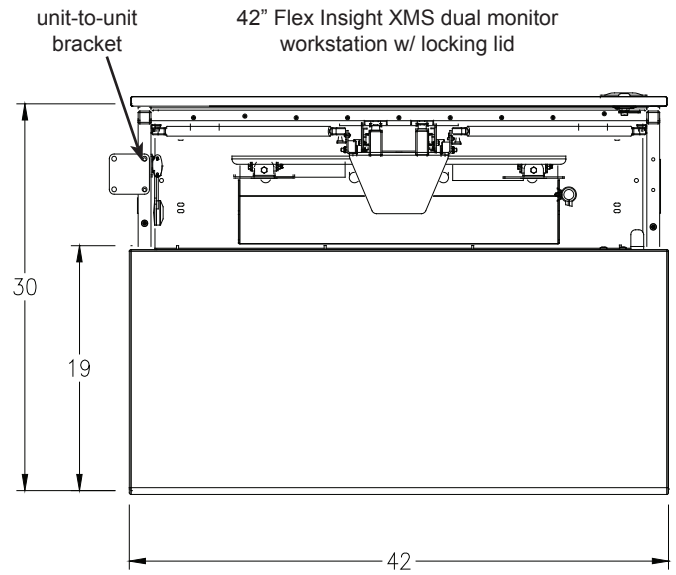

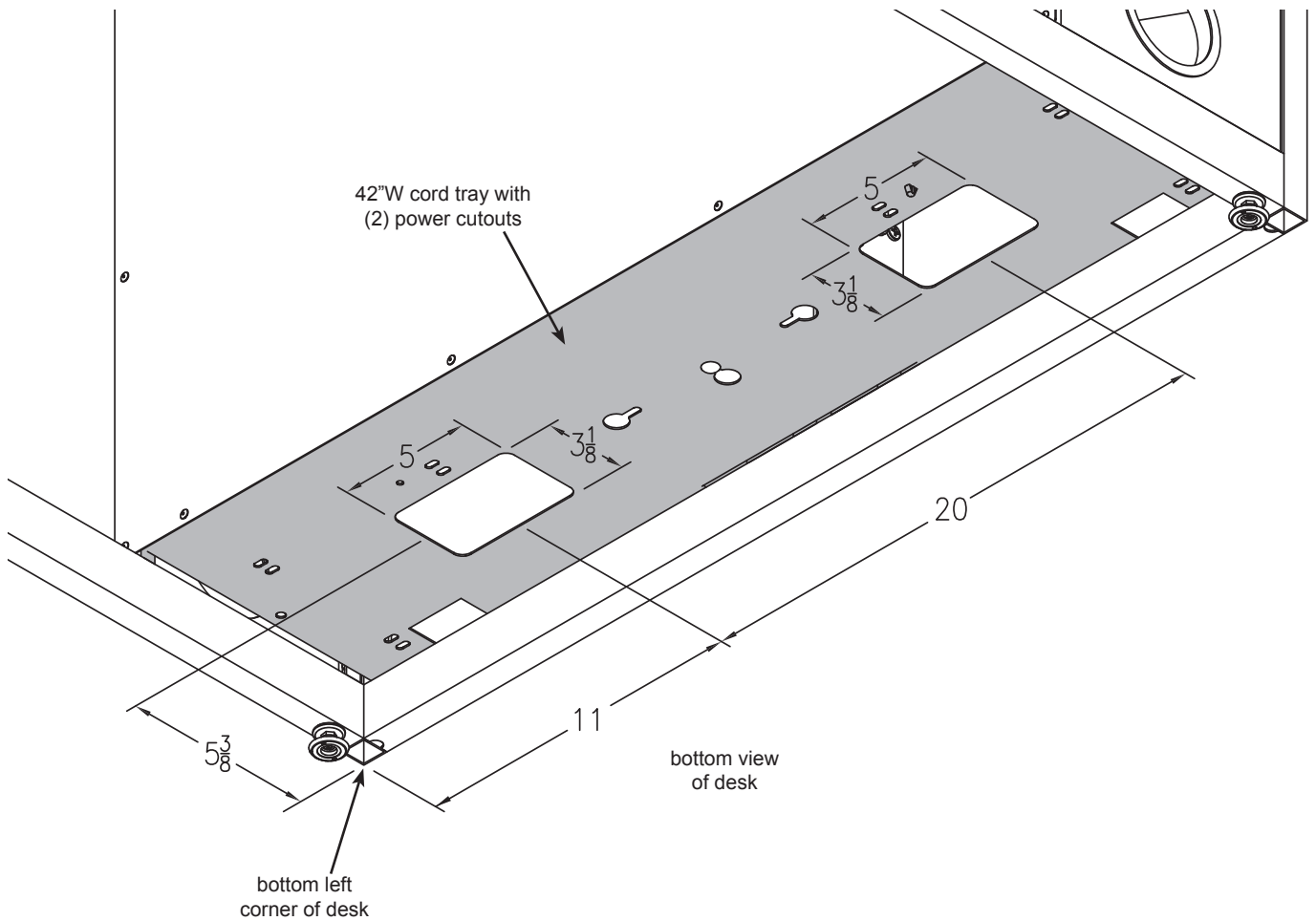
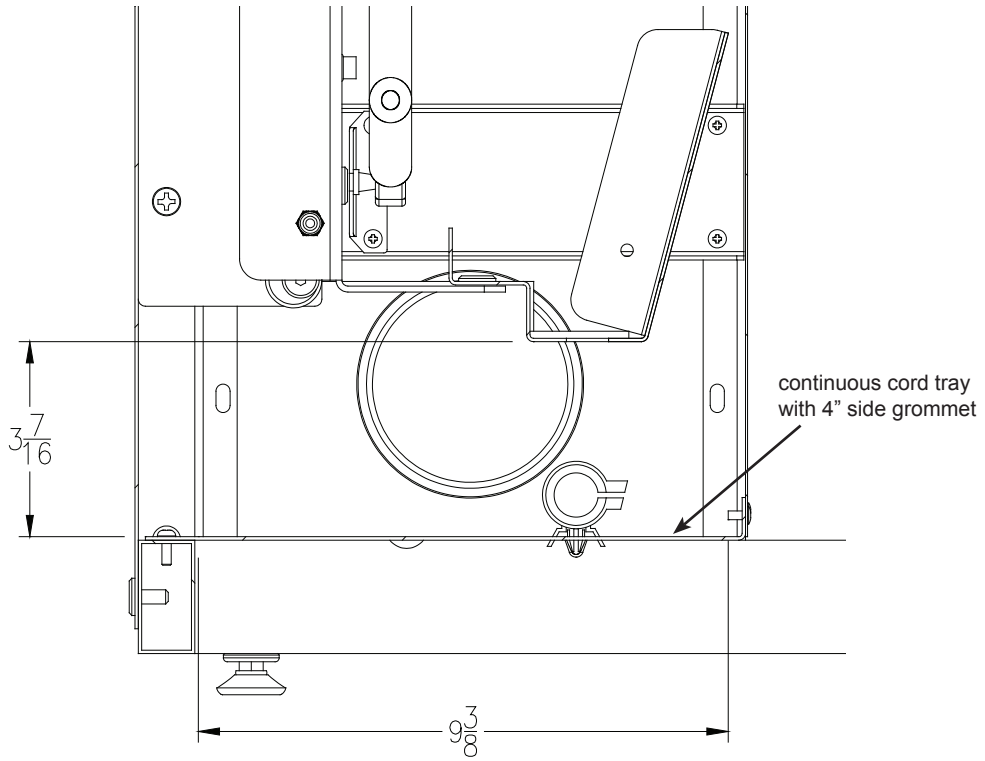

Options

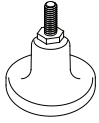

1" Bell Glide Riser Kit
 raises worksurface height from
 29" to 30" (set of 4)
 98513



7-Outlet Power Strip, insured
 w/ surge protector, and 15' cord
 12"W x 2"D x 1 $\frac{5}{16}$ "H
 99024



Monitor Counterbalance Kit
 (for lighter monitors)
 kit includes (2) 2.5 lb weights
 38965

| Nominal weight of both monitors | Counterbalance |
|---------------------------------|---------------------------------|
| 14-17 lbs | use 4 weights (requires 2 kits) |
| 17-20 lbs | use 3 weights (requires 2 kits) |
| 20-24 lbs | use 2 weights |
| 24-27 lbs | use 1 weight |
| 27-32 lbs | not required |

Warranty

WE WILL MAKE IT RIGHT FOR YOU!

Spectrum is committed to provide complete customer satisfaction. Each of our products are manufactured from the best materials available and each product is stringently monitored throughout the production process through our P.A.C.E. program (Product Assurance to meet Customer Expectations). Our Customer Service Help Line 1-800-235-1262 is ready to provide immediate attention to any questions, comments or concerns. We are available to answer your calls Monday through Friday from 7 am to 5 pm CST, excluding observed holidays. In addition your product comments or concerns are welcome via e-mail at: spectrum@spectrumfurniture.com.

Warranty Statement

We guarantee all Spectrum products to be free of all defects in materials and workmanship, for the original owner, for a period of ten years. Any item deemed defective by Spectrum or the original manufacturer, under normal use conditions, will be repaired or replaced at Spectrum's discretion. This warranty applies to all products manufactured and distributed by Spectrum except the products listed below.

Items that have a varying warranty include, but are not limited to, the following:

- Adjustable Crank/Electric Desk Legs (1 yr)
- Flat Panel Desk Gas Cylinders (1 yr)
- Upholstered Soft-Goods (5 yrs)
- Adjustable Height & Stacking Chair Parts – including frames, gas cylinders, wood and plastic parts, and control handles (7 yrs)
- Adjustable Height & Stacking Chair Casters (2 yrs)
- Chair Upholstery & Textiles (2 yrs of normal use of Soft Goods, Adjustable Height, Stacking, Wood and Metal Chairs)
- Chair Upholstery - Graded-In Fabrics and C.O.M (no warranty)
- Height Adjustable Columns and Lifts (1 yr)
- General Use Casters (1 yr)
- Electrical – Electri-Pak, Power Communication Modules, and special order ECA electrical items (1 yr)
- Electrical - Power Strips & Electrical Timers (1 yr)
- Electrical Surge Suppressors (lifetime)
- Electrical - Retractable Power Cords (1 yr)
- Keyboard/Mouse Trays (1 yr)
- Flat Panel Monitor Arm – General Parts (5 yrs)
- Flat Panel Monitor Arm – Gas Cylinders (2 yrs)
- CRT Monitor Arm (1 yr)

Warranty is void if product is not used for its intended purpose or subjected to an unusual application, multiple-shift use, alteration, accident, abuse or abnormal wear and tear. Representations of colors on-line and in printed materials are meant to be a close reference to the actual colors but not an exact match. Slight variations in color and texture of wood stains, powder coating, laminates, fabrics and other materials are normal in different manufacturing lots; as such these variations are not considered defects.

DESIGNED FOR INDOOR USE ONLY – Unless specifically stated in the product specifications, Spectrum's products have been designed and constructed for indoor use only. Moving or using outdoors, or on excessively rough surfaces, may cause damage to the products and will void the warranty. If an outdoor application is desired please contact us to discuss potential custom design solutions.

The warranty, as stated above, supersedes any previous warranties and is effective as of 9/1/2010

Touchboards

205 Westwood Ave, Long Branch, NJ 07740
Phone: 866-94 BOARDS (26273) / (732)-222-1511
Fax: (732)-222-7088 | E-mail: sales@touchboards.com

