

REVERSIBLE BOARDS

Aluminum Framed

Touchboards

205 Westwood Ave, Long Branch, NJ 07740
 Phone: 866-94 BOARDS (26273) / (732)-222-1511
 Fax: (732)-222-7088 | E-mail: sales@touchboards.com

ghent

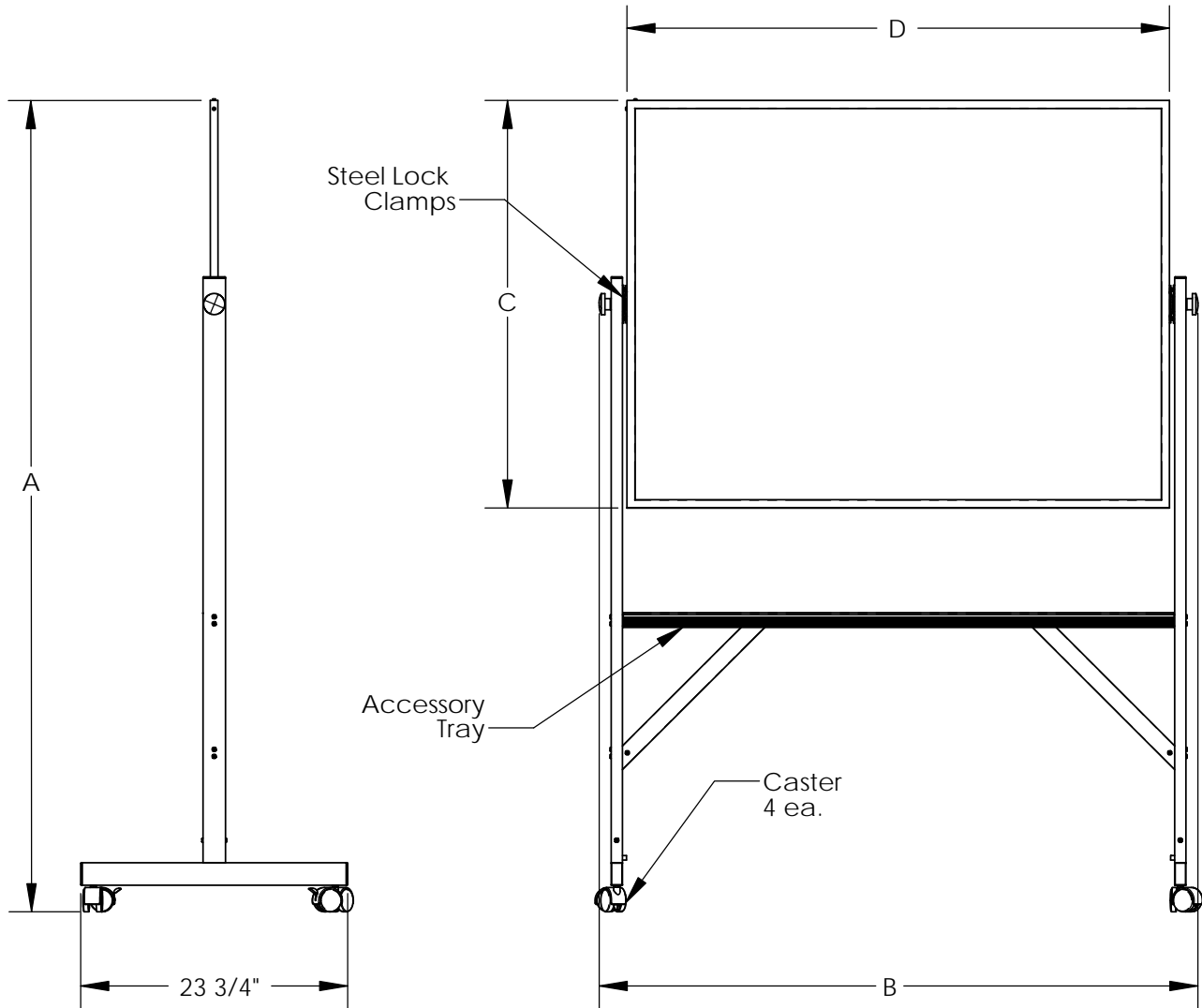

Materials:

- Framework: Satin anodized aluminum extrusion.
- Writing surfaces: Marker board - white enamel applied to 1/8" hardboard.
 Chalk board - green carborundum slating applied to 1/8" hardboard.
 Tack board - natural cork applied to 3/8" fiberboard
- Swivel casters are black thermoplastic with wheel locks.

Features:

- Available in two board sizes: 36"H x 48"W and 48"H x 72"W
- Board surfaces combinations available: chalk/chalk, chalk/cork, marker/chalk, marker/marker, marker/cork, and cork/cork

Notes:

- All board surfaces are non-magnetic
- Indoor use only

ITEM NUMBER	A	B	C	D
ARCC34, ARCK34, ARMC34, ARMM34, ARMK34, ARKK34	72-1/8"	53-1/4"	36-1/4"	48-1/4"
ARCC46, ARCK46, ARMC46, ARMM46, ARMK46, ARKK46	78-1/8"	77-1/4"	48-1/4"	72-1/4"