

Assembly Instructions

⚠ Important ⚠

Before you begin, read and comply with all safety and operating instructions, and ensure all parts and correct quantities are included.

Any parts damaged during shipment must be reported within 15 days of receipt. To report information regarding missing parts or damage, to purchase parts or accessories, or if you have any questions, please contact us.

www.spectrumfurniture.com
800-235-1262, 715-723-6750

Thank you for purchasing Spectrum products!

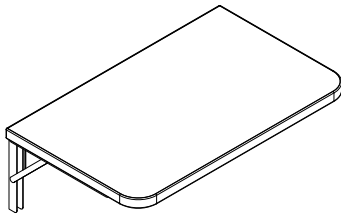

(1) 0118912
Flip-up shelf
assembly



(6) 0100167
8-32 x 1/2" PH
Thread-cutting
screw

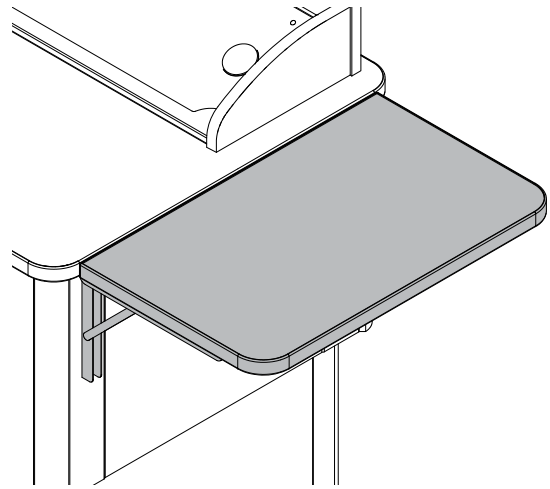

Flip-up Shelf for Freedom XRS Elite™ 55333

Installation



1. Determine which side of the lectern you want the shelf installed.
2. Extend and lock the folding shelf brackets into the horizontal position. **Figure 1.**
3. Align and attach each bracket to the side of the lectern with (3) 8-32 x 3/8" PHM screws. A second person will help by supporting the shelf during installation.
4. Tighten screws securely.

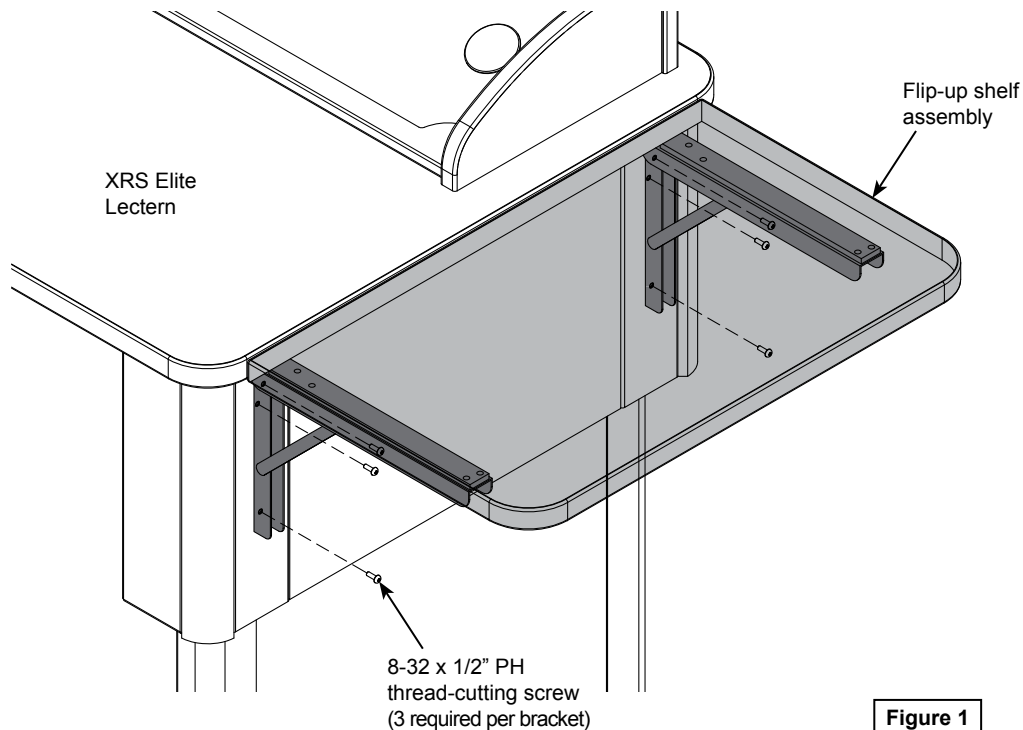

Note: Do not exceed
50 lb [22.7 kg] of
weight on the shelf.

Figure 1