



The **LFT7000WM-S** heavy duty wall mounted lift for single large TV's and interactive displays. While anchored to a wall, its designed to keep the weight of unit and display on the floor. Ideal for environments where adjustable height or ADA is required. Internally it features vertical 3U rack rails behind the bottom locking panel. Cable channel and ventilation. Requires fastening to stud or masonry wall.

### Standard Features

- Accommodates up to 42" to 80" monitors (280 lbs max - 800x400mm VESA max)
- 20" travel electric Worm-Drive actuator for safety and reliability
- Cable push-button remote for easy incremental adjustments
- Includes wall anchoring hardware for masonry and stud walls
- Removable locking front panels with wiring channel inside main pillar
- Scratch resistant powder coat finish
- Grey metal frame with Shark Grey-SGT panel color
- 3U vertical rack inside

### Options

- **TVCB-XL** Camera bracket (For video conference applications allowing camera to ride up & down with the screen)
- **CBB-TV** Under TV camera bracket (26" - 80" TV's)
- **PB** Six outlet power bar with 10 ft. cord

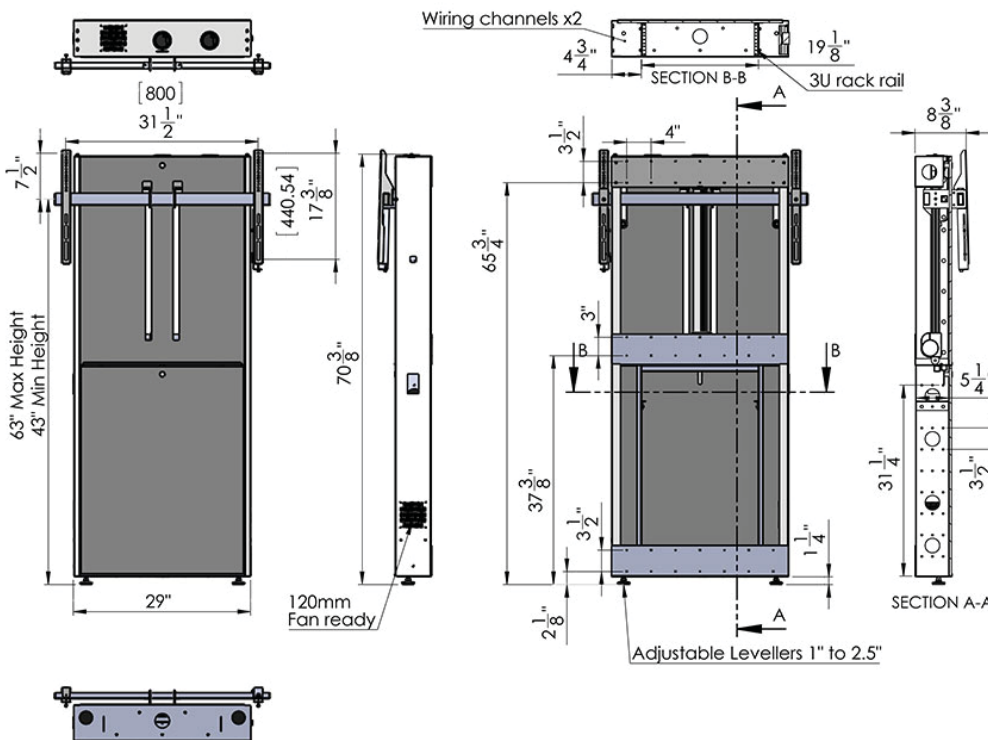

### Specifications

**Model:** LFT7000WM-S  
**Width:** 35"  
**Depth:** 9"  
**Height:** 70"

### Colors

Grey metal frame with Shark Grey-SGT panel color



205 Westwood Ave, Long Branch, NJ 07740  
 Phone: 866-94 BOARDS (26273) / (732)-222-1511  
 Fax: (732)-222-7088 | E-mail: sales@touchboards.com

The information contained in this drawing is the sole property of Audio Visual Furniture International. Any reproduction in part or as a whole without the written permission of Audio Visual Furniture International is prohibited. We can build or modify stock configurations to suit customer specifications. Please contact us to discuss how this service can help meet your needs. Some quantity restrictions may apply. Specification subject to change without notice. Computers, cameras, monitors, etc. are shown to illustrate product usage and are not included unless otherwise noted.