

## Step 7a

Install Non-skid Pads on the top of the Trolley Trunk Covers to cushion the edge of each Trunk Assembly where it meets the cover. Install pads on the inside face of the cover, at the edge, about 3.5" below the threaded holes at the top of the cover.



Non-Skid Pad  
175-5068-03

## Step 7b

**STOP: IF YOU PURCHASED A TROLLEY EQUIPMENT SHELF, ADDITIONAL WOOD SHELF, OR TROLLEY TRAY READ THOSE INSTRUCTIONS BEFORE INSTALLING THE TRUNK COVERS.**

Install the Trolley Trunk Covers by orienting both Covers with the Trunk Assemblies.

Secure the top and bottom of each Cover using a total of four Button Head Screws per Cover.



(1/4-20 X .375") Button Head Screw  
325-5210-00

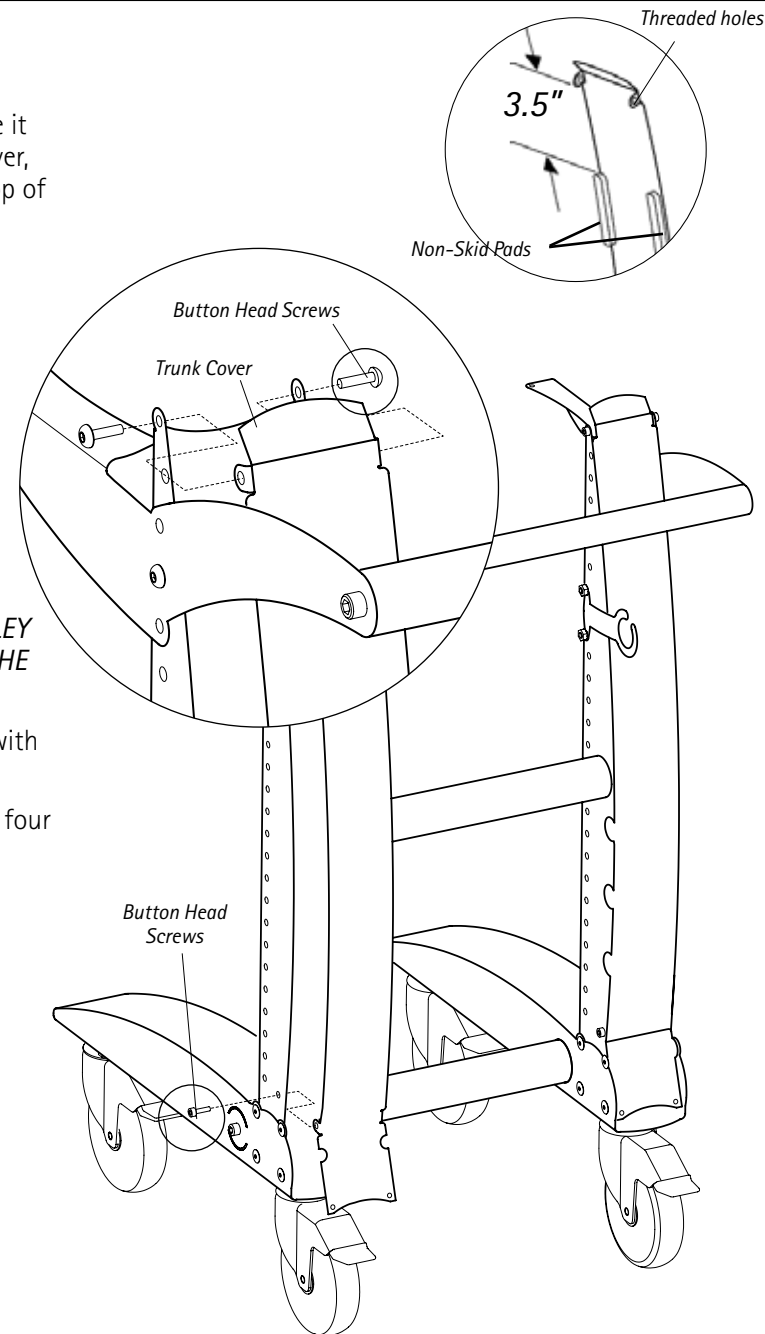

## Step 8

**STOP: IF YOU PURCHASED A SWING OUT MOUSE SHELF READ THOSE INSTRUCTIONS BEFORE INSTALLING THE TOP.**

Finally, place the main Trolley Shelf onto the installed Shelf & Handle Sides, aligning the six holes on the Shelf with those on the Sides.

Secure the Shelf to the Sides using a total of six 3/4" Wood Screws. Tighten all Screws and Nuts.

**Congratulations!** Your assembly is complete!



3/4" Wood Screw  
325-5106-00

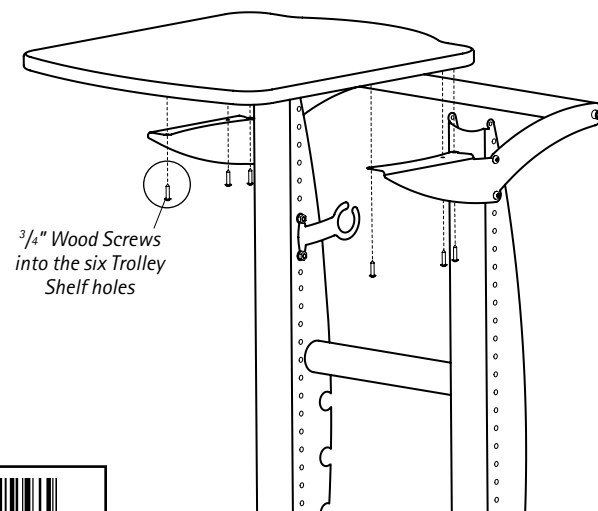

Questions?



300-5225-00

1-800-325-3841

# Touchboards

205 Westwood Ave, Long Branch, NJ 07740  
Phone: 866-94 BOARDS (26273) / (732)-222-1511  
Fax: (732)-222-7088 | E-mail: sales@touchboards.com



## Trolley Cart Assembly Instructions

Hello!

Thank you for choosing Anthro.

Before beginning assembly of your Trolley, please take a moment to re-view the parts listed below to verify that your shipment is complete.

All fastener quantities shown are the minimum needed for this assembly. There may be a few extras provided which are not required.

The following Tools (not shown at right) have been provided:

- Hex Driver 5/32" .....375-5000-00
- Hex Key 6mm.....375-5013-00
- 3/16" Allen Key.....375-5028-00
- 3-way Wrench.....225-5196-03
- 5/32" Driver Bit.....375-5003-00

### Component list for part # TR18zz/xx and TT18zz/xx.

01- Trolley Trunk Assembly (X) ..... Qty. 1.....		
TR18zz/xx.....	835-5018-00	
TT18zz/xx.....	835-5401-00	
02- 5" Total Lock Casters..... Qty. 2 .....	150-5081-00	
03- 5/16-18 Button Head Screw ..... Qty. 16.....	325-5188-00	
04- 5/16-18 X 1" Tube Screws ..... Qty. 4 .....	325-5136-00	
05- 5" Swivel Lock Casters ..... Qty. 2 .....	150-5080-00	
06- Trolley Trunk Covers..... Qty. 2 .....		
TR18zz/xx.....	225-5753-00	
TT18zz/xx .....	225-4278-00	
07- 18.25" Lower Cross Tube..... Qty. 1.....	125-5244-xx	
08- Trolley Trunk Assembly (Y) ..... Qty. 1.....		
TR18zz/xx.....	835-5019-00	
TT18zz/xx .....	835-5402-00	
09- 12" Upper Cross Tube ..... Qty. 1.....	125-5243-00	
10- Trolley Cable Wraps..... Qty. 2.....	225-5756-00	
11- 1/4-20 Keps Nuts..... Qty. 6.....	325-5202-00	
12- 18" Handle..... Qty. 1.....	125-5245-00	
13- Shelf & Handle Side (X)..... Qty. 1.....	225-5754-00	
14- 18.5" Wide Trolley Shelf..... Qty. 1.....	100-6495-00	
15- Shelf & Handle Side (Y)..... Qty. 1.....	225-5755-00	
16- 3/4" Wood Screws..... Qty. 6.....	325-5106-00	
17- 1/4-20 Button Head Screws ..... Qty. 14.....	325-5210-00	
18- 1/4-20 X 2" Handle Screws ..... Qty. 2.....	325-5034-00	
19- Non-Skid Pads (not shown)..... Qty. 8.....	175-5068-03	

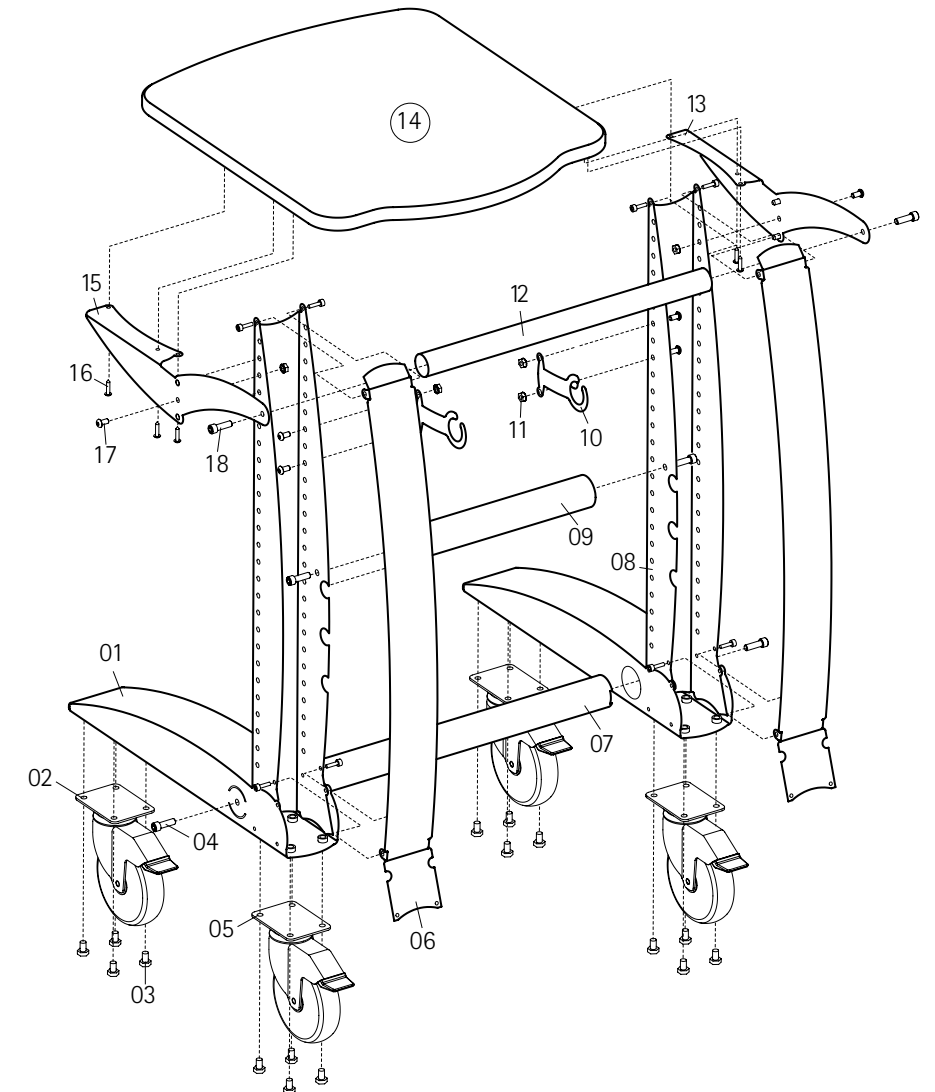

**Step 1**

BEFORE YOU BEGIN, take special notice of the features on the Swivel Lock Casters (those with the Green Brake Pedals).

The teeth on the plate of both Swivel Lock Casters need to face the rear of the Trunk Assemblies.

Step 2 will give further instructions about securing the Casters to the Trunk Assemblies.

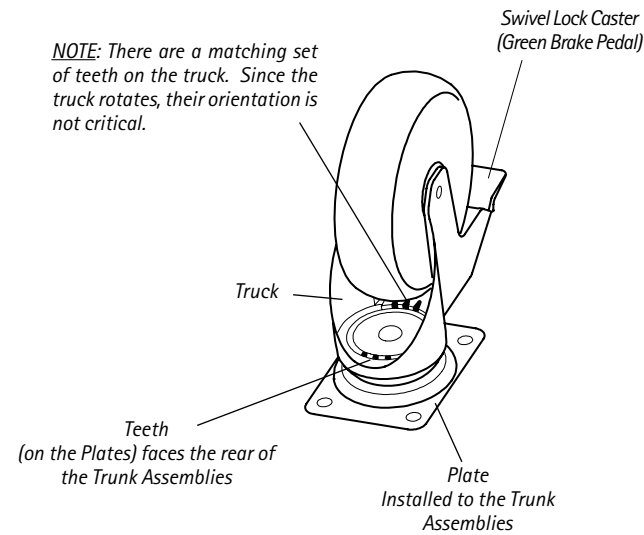

**Step 2** (requires the 3-Way Wrench)

**STOP: IF YOU PURCHASED A TROLLEY BASE SHELF, READ THOSE INSTRUCTIONS NOW.**

Install all four Casters to both Trunk Assemblies using four Button Head Screws per Caster.

DOUBLE CHECK THE INSTALLATION of the Swivel Lock Casters (Green Brake Pedal) by positioning the Trunk Assembly & Caster as shown. Then depress the Brake. If it is installed correctly, the Caster will be locked in a parallel orientation (as shown) with the Trunk Assembly.

**NOTE:** Make certain to install one Swivel Lock Caster (green brake) and one Total Lock Caster (black brake) onto each Trunk Assembly.

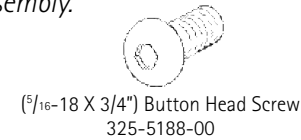
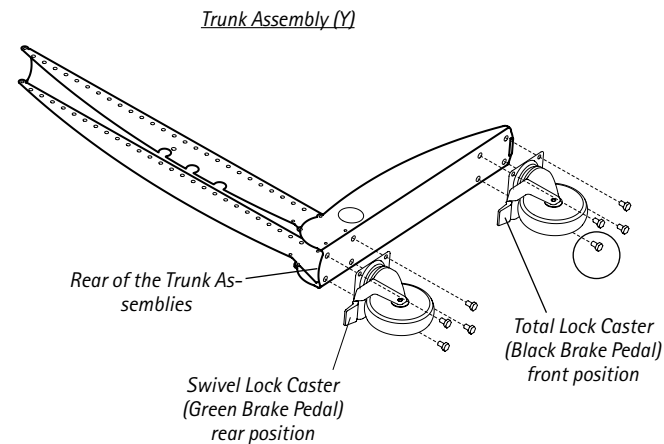

**Step 3** (requires the 6mm Hex Key)

Position both Trunk Assemblies and the 18" Lower Cross Tube as shown.

Insert the 18" Cross Tube into the Large Holes of each Trunk and loosely attach the Tube to each Trunk using one Tube Screw per end.

**NOTE:** The 18" Cross Tube ends are keyed to fit into the Trunk Assemblies.

**NOTE:** If you purchased a Trolley Base Shelf, install the Casters to the Trunk Assemblies during this Step.

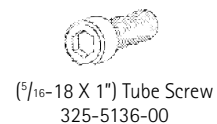
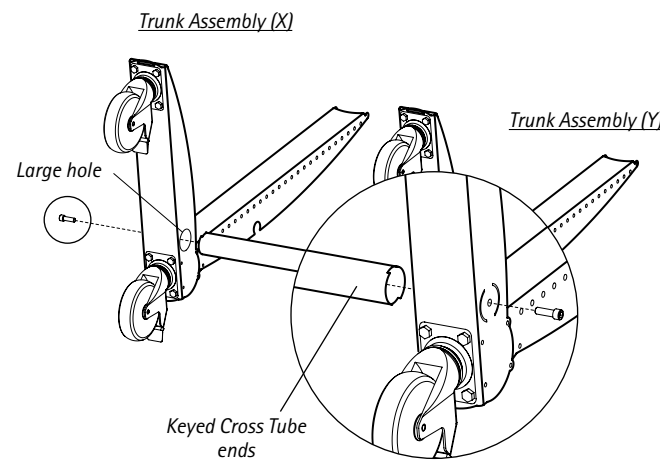

**Step 4** (requires the 6mm Hex Key)

Rotate the Cart Assembly (from Step 3) onto the Casters.

Place the 12" Upper Cross Tube between each Trunk Assembly and align the Tube with the Large hole, midway up the Trunk.

Carefully secure into place using one Tube Screw per end.

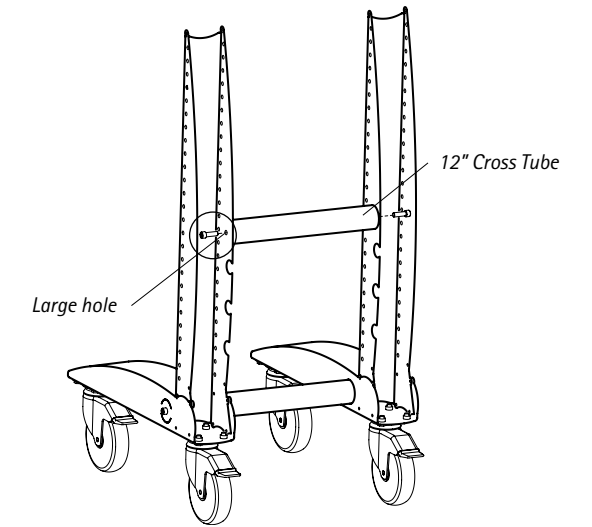
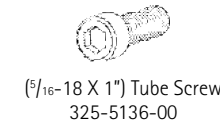

**Step 5** (requires the 3-Way Wrench)

Position one Trolley Shelf & Handle Side against a Trunk Assembly. Insert the two posts of a Side into holes 3 & 5 (from the top) of the Trunk. Loosely attach the Side to the Trunk with one Button Head Screw and Keps Nut. Repeat for the other Side.

Place the Trolley Handle between both Sides. Insert a Handle Screw through both ends of the Side and carefully thread into the Handle. Tighten the Button Head Screws on the Sides.

**NOTE:** By installing the Side posts into holes 3 & 5, your final Shelf height will be 36" from the floor.

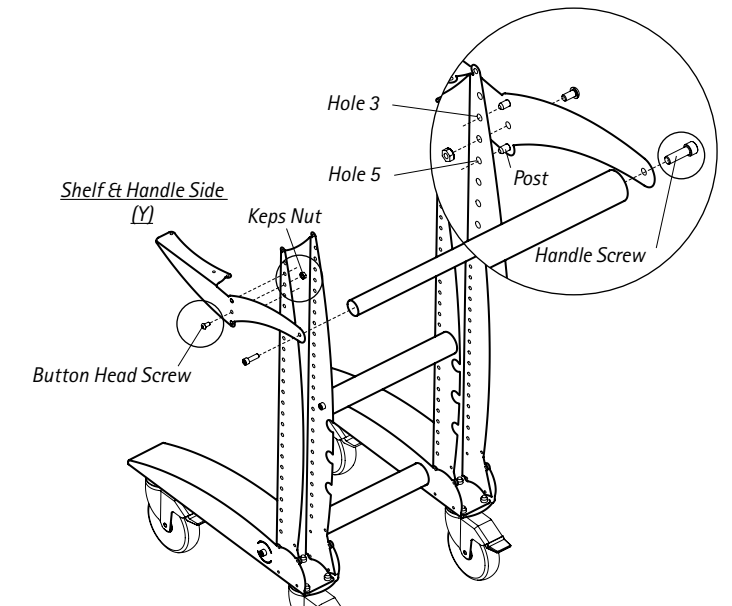

**Step 6** (requires the 3-Way Wrench)

Determine the location for your Trolley Cable Hangers, then position one against a Trunk Assembly.

Insert two Button Head Screws through the Cable Hanger and capture on the opposite side using two Keps Nuts.

Repeat for remaining Cable Hanger.

