

3M

1700 Series

Overhead Projector
Operator's Guide

Série 1700

Rétroprojecteur
Guide de l'utilisateur

Serie 1700

Retroprojector
Manual del Operador

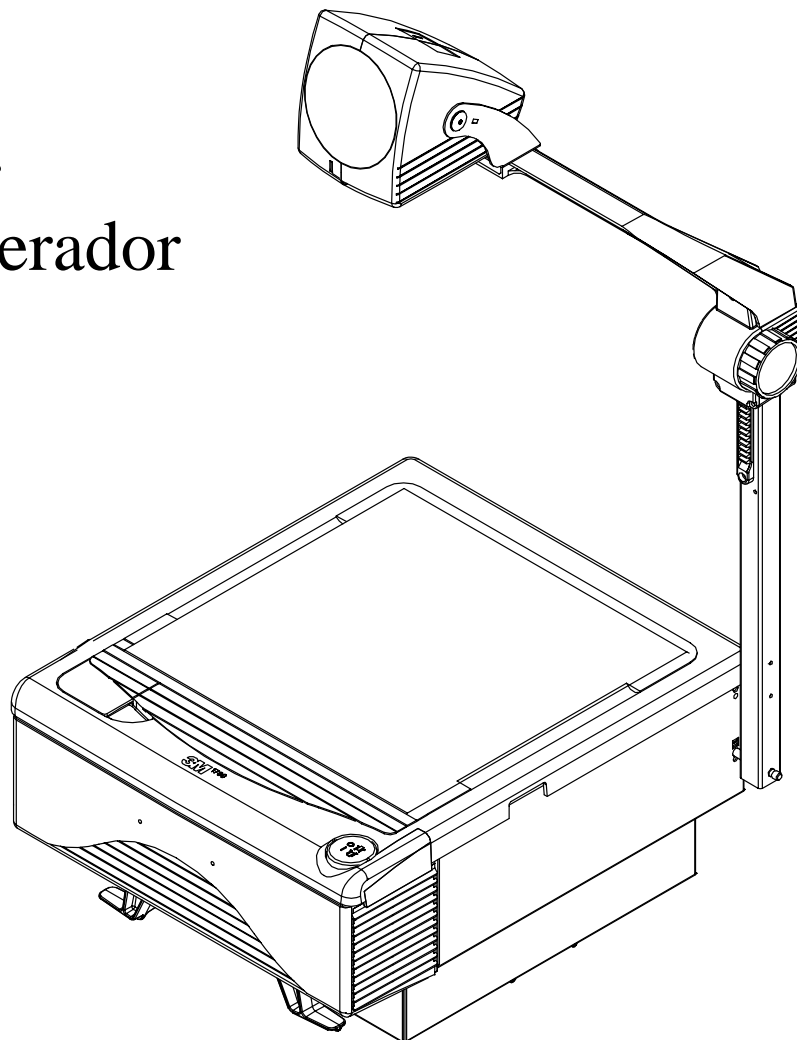

INTENDED USE

Before operating the machine, please read the entire manual thoroughly. The 3M™ Overhead Projector 1700 was designed, built and tested for use indoors, using 3M brand lamps and nominal local voltages. The use of other replacement lamps, outdoor

operation or different voltages has not been tested, and could damage the projector or peripheral equipment and/or create a potentially unsafe operating condition.

IMPORTANT SAFEGUARDS

When using your photographic equipment, basic safety precautions should always be followed, including the following:

1. Read and understand all instructions before using. Pay particular attention to areas where this symbol \triangle is shown.
2. Close supervision is necessary when any appliance is used by or near children. Do not leave appliance unattended while in use.
- \triangle 3. Care must be taken as burns can occur from touching hot parts.
- \triangle 4. Do not operate appliance with a damaged cord or if the appliance has been dropped or damaged — until it has been examined by a qualified serviceman.
- \triangle 5. Position the cord so that it will not be tripped over, pulled or contact hot surfaces.
6. If an extension cord is necessary, a cord with a current rating at least equal to that of the appliance should be used. Cords rated for less amperage than the appliance may overheat.
7. Always unplug appliance from electrical outlet before cleaning and servicing and when not in use. Never yank cord to pull plug from outlet. Grasp plug and pull to disconnect.
- \triangle 8. Let appliance cool completely before putting away or when replacing lamp. Loop cord loosely around appliance when storing.
9. To reduce the risk of electric shock, do not immerse this appliance in water or other liquids.
10. To reduce the risk of electric shock, do not disassemble this appliance, but take it to a qualified technician when service or repair work is required. Incorrect reassembly can cause electric shock when the appliance is used subsequently.
11. The use of an accessory attachment not recommended by the manufacturer may cause a risk of fire, electric shock, or injury to persons.
12. Connect this appliance to a grounded outlet.
13. Disconnect this unit from its source of supply before replacing the projection lamp.
- \triangle 14. This unit is equipped with optical lenses and should not be exposed to direct sunlight.
15. Keep ventilation openings free of any obstructions.
16. This unit is assembled with a special power cable that, if damaged, must be replaced by the same type of cable. This power cable can be ordered from your local 3M Visual Systems Division Dealer and must be installed by a serviceman.

SAVE THESE INSTRUCTIONS

The information contained in this manual will help you operate and maintain your overhead projector.

Setup Instructions

1. Remove bolts (1) from projector body.
2. Align post holes (2) with mounting holes on projector.
3. Insert bolts (3) through post holes and turn finger tight.
4. Use wrench (4) to tighten bolts and secure post to projector body.

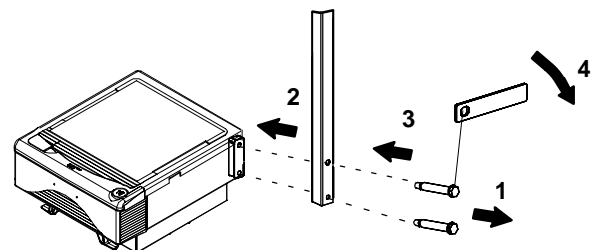

✔ Note

Post bolt wrench (4) is taped to the projection post.

✔ Important

Tighten bolts (1) with equal pressure.g

Product Description and Machine Characteristics

The 3M™ Overhead Projector 1700 Series is designed to be safe, efficient and easy to use.

It features a safety interlock that shuts off power to the lamp when the cover is open, a thermostat to prevent overheating, a quiet and efficient cooling system, a closed head with singlet lens, an ENX

lamp system, a lamp changer (if equipped), a cord wrap, a fixed post and easily accessible focus knob and on/off switch.

Refer to the illustration below to identify the external machine characteristics for this projector.

Part Identification List

1. Closed Projection Head
2. Singlet Lens
3. Focus Knob
4. Fixed Post Assembly
5. Top Cover Release
6. On/Off Switch
7. Cord Wrap
8. Control Panel
 - a. Lamp Changer
 - b. Lamp Interrupt Switch
9. Top Cover
10. Stage Glass

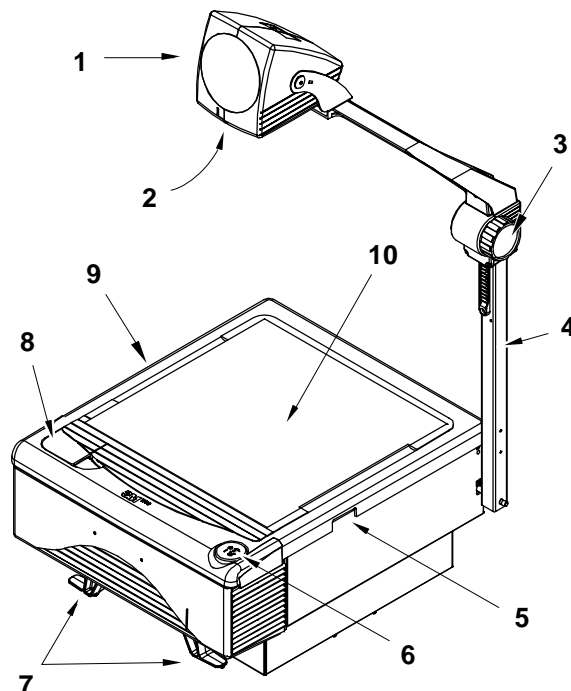

Electrical: 120 VAC 60 Hz

Cleaning

For best performance, use 3M™ Overhead Cleaner 676 to keep your projector free of excess dust and surface dirt.



70-0705-6877-2

⚠ Caution

Cleaning the underside of the stage glass or Fresnel lens is not recommended. Improper cleaning or disassembly can **damage the optics**. Contact your 3M Dealer or Service Center for assistance.

Daily Cleaning

Use a soft cloth to remove dust from the stage and projector base areas.

Stage Glass and Lenses

Use 3M™ Overhead Cleaner 676 to remove surface dirt from the stage glass and projector lens.

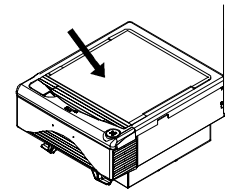
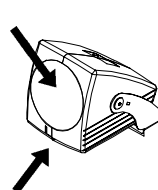

Operating Instructions

Read the Important Safeguards before operating this projector.

1. Position projector in front of the projection screen.
2. Plug power cord into electric outlet.
3. Push power switch (4) "On" to illuminate lamp.
4. Rotate projector (1) until projected light beam is perpendicular (90°) to the screen surface. The height at the left and right sides of the projected image should be equal.

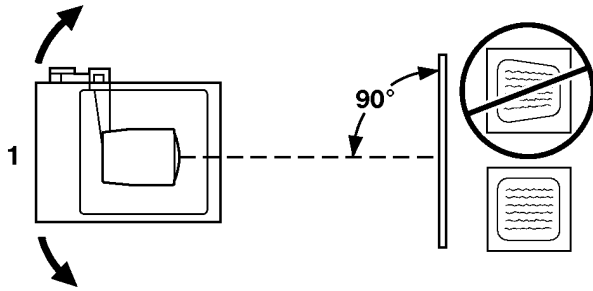

⚠ Caution

Do not look directly into the path of the projection lamp when it is illuminated. The light is very bright and prolonged exposure could cause **damage to your eyesight**.

5. Adjust angle of projection head (2) to raise or lower the image on the screen.

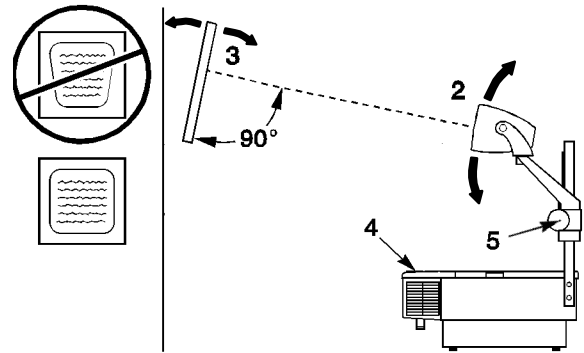

6. For best results, tilt projection screen (3) toward projector until the width of the projected image is equal at both the top and bottom.
7. Rotate focus knob (5) to obtain clearest image.
8. Push power switch (4) to "off" and unplug unit when not in use.

✔ Note

An LCD projection panel is not recommended for use with this projector.

Lamp Changer

If the primary lamp burns out, rotate lamp changer dial to select the second lamp.

1. Open control panel door (1).
2. Lamp interrupt switch (2) cuts power to lamp.
3. Rotate lamp changer dial (3) to select alternate lamp. Turn dial fully until it stops.
4. Close control panel door to illuminate lamp.

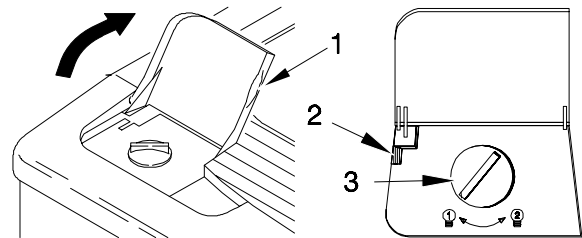

✔ Important

Lamp will not illuminate unless control panel door is completely closed.

Color Tuning Dial

Rotate the color tuning dial (if equipped) to eliminate the yellow/orange to brown or blue corners on the screen.

1. Rotate dial to the left to remove blue corners.
2. Rotate dial to the right to remove yellow/orange to brown corners.

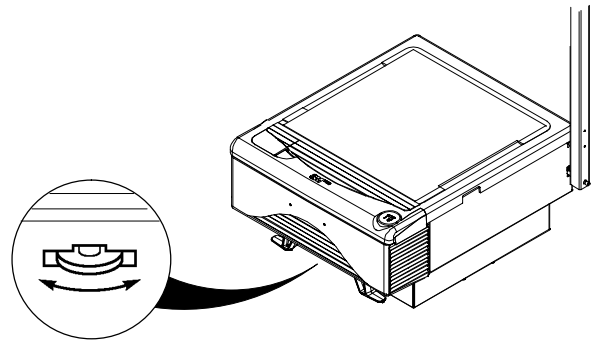

Lamp Replacement

Use the proper lamp type for your projector.



ENX – 82V, 360W
78-6969-8027-1

To replace the lamp:

1. Turn projector off and unplug (1) the power cord.
2. Allow projector lamp and metal parts to cool.
3. Release cover latch (2) and lift up top cover to access lamp (3).
4. Depress lever (4) to release lamp. Discard old lamp.
5. Push new lamp (5) fully and squarely into socket.
6. Close the top cover.

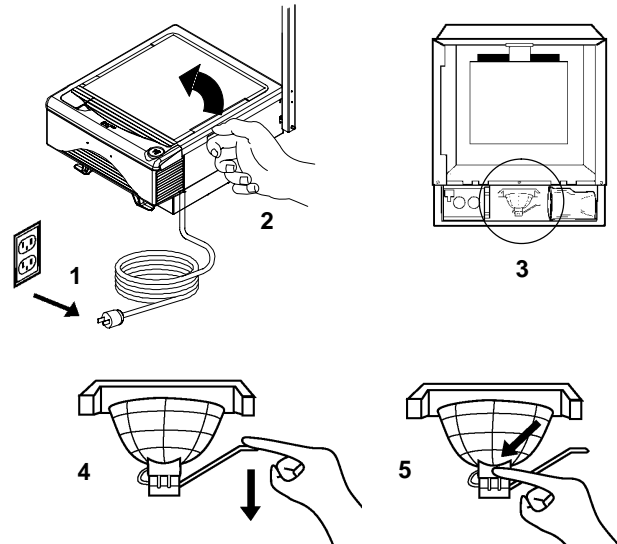

Caution

To avoid **burns to the fingers**, allow projector parts to cool before replacing lamp.

Caution

Use care when placing hands inside projector body. Sharp or rough edges could cause **abrasions or cuts to fingers**.

Caution

If a lamp cracks or breaks and deposits glass fragments inside the projector body, use a vacuum cleaner to remove. Touching sharp glass could result in **cuts to your fingers**.

Caution

When the top cover is in the open position, use care not to tip it over. If the cover slams shut, it could result in **pinching or bruises to your fingers**.

Troubleshooting

Problem	Probable Causes	Solution
A new lamp has been installed and neither lamp nor fan energize	a. Projector not plugged in b. No power at wall outlet c. Top cover not completely closed	Make sure unit is plugged into outlet supplied with power, top cover is completely closed and latched.
Lamp does not illuminate but fan motor runs	a. Lamp is not seated properly in socket b. Lamp is burned out	Seat lamp fully and squarely into the lamp socket. If lamp still does not illuminate, replace it.
After replacing a burned out lamp, the new lamp fails	a. Defective lamp was installed b. Possible electrical problem	Replace lamp again. If second lamp fails immediately, you may have an electrical problem. Call service to have projector checked.
Short lamp life. Lamps seem to fail before expected life span of 130 hours (typical)	a. Defective lamp b. High line voltage	Monitor actual lamp life with daily log. If early lamp failure continues, call service to have projector checked.
Fan motor does not run but lamp illuminates	a. Fan blade/motor is obstructed b. Fan motor is burned out	Call service to have projector checked.
Projected image is wider at the top or on one side of the screen	Screen surface is not perpendicular to projected image	Tilt projection screen until it is perpendicular (90°) to the projected image.
Projected image is dim	Dirty stage glass, lenses or optical surfaces	Follow cleaning instructions to remove surface dirt.
Projected image does not have uniform brightness	Lamp is not seated properly in socket	Seat lamp squarely into the lamp socket.
Color, focus, image problems	Optics out of alignment	Call for service.

Service Information



In the U.S. and Canada, please call us for:

- Product information
- Product assistance
- Technical assistance
- Service locations

If you need product assistance or service, contact your dealer or:

1-800-328-1371

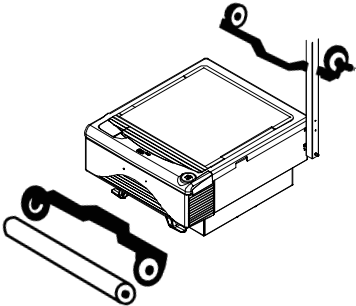
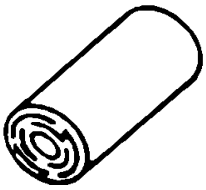
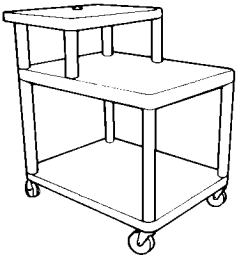
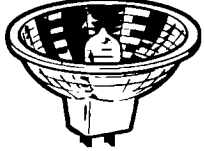
Accessories – Accessoires – Accessorios – Acessórios

 <p>Roller Attachment – 10 1/4" (260 mm) Attachment à roulettes Accesorio para el rodillo Acessórios para o rolo (260 mm) 78-6969-7214-6 HA5760</p>	 <p>Write-on Film Roll Rouleau de pellicule à écrire Rollo de Película para Escribir Rolo e Película para Escrever 78-9020-1282-8 – 10 1/4 " (260mm) AF4310</p>	 <p>Overhead Presenter's Cart Chariot pour rétroprojecteur Carro para Presentación del Proyector Carro para o Retroprojeto 78-6969-7217-9 HA5651</p>
 <p>Lamp Lampe Bombilla Lâmpada ENX – 78-6969-8027-1 HA6000</p>	 <p>Overhead Cleaner Nettoyant pour rétroprojecteur Limpiador de retroproyectors Limpador de Retroprojetores 70-0705-6877-2</p>	

3M

Visual Systems Division



Visual Systems Division

Boulevard de l'Oise
95006 Cergy Pontoise Cedex
France

Printed in U.S.A.
E3M 8/96 78-6970-7515-4