

PLINTH FLOOR STAND

PSD-PL48 / PSD-PL60
PSD-SHP (optional shelf)



205 Westwood Ave, Long Branch, NJ 07740
Phone: 866-94 BOARDS (26273) / (732)-222-1511
Fax: (732)-222-7088 | E-mail: sales@touchboards.com



Plinth: Comes covered in a lustrous silver powder coat finish. The plinth features a low-profile base and flush mounting fascia to conceal cables. Available in both 48" and 60" average screen-center viewing heights.

PLINTH STAND DIMENSIONS

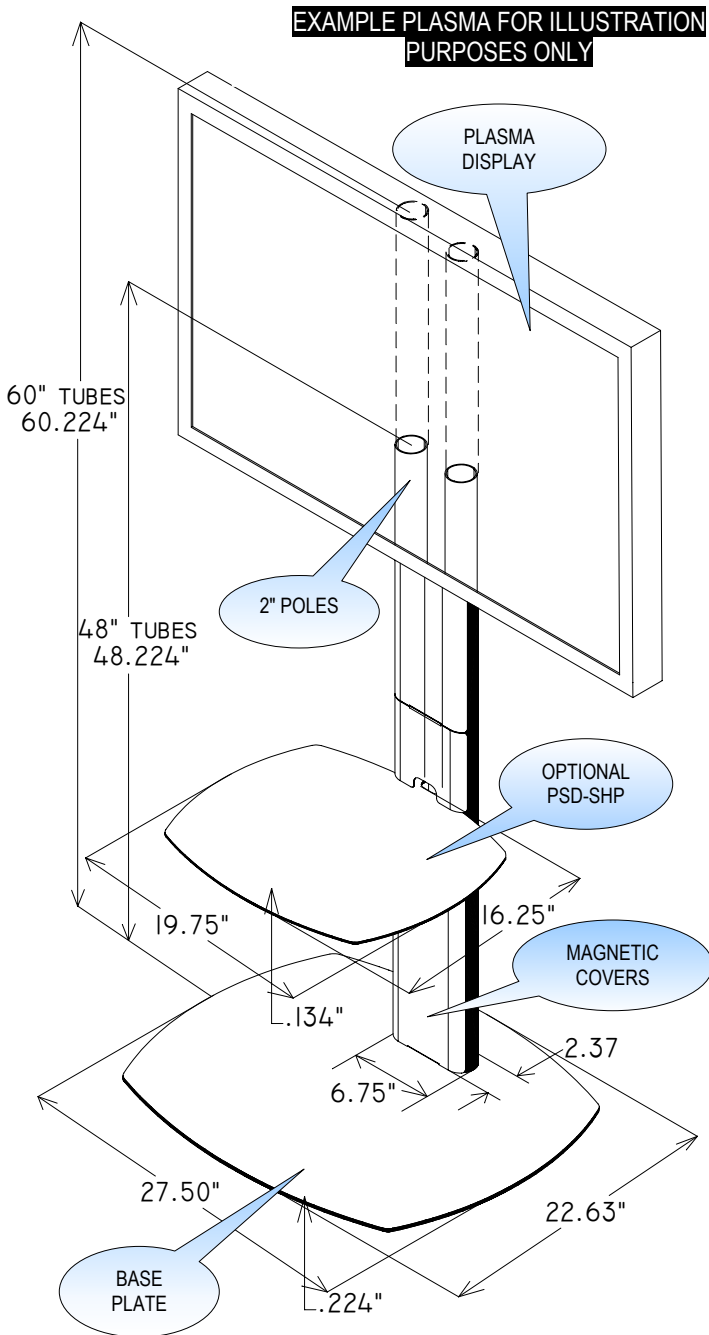

Installation procedures

Step 1

Place the floor stand on a flat surface. Insert the two (2) 2" chrome poles into the two (2) tube clamps on the base. Make sure the screws access hole cutouts are in the rear of the base. Secure the two (2) 10 (mm) "cup point" set screws one on each side of the tube clamps with the M10 Allen wrench to secure the tubes to the base. See fig 1.

Fig 1

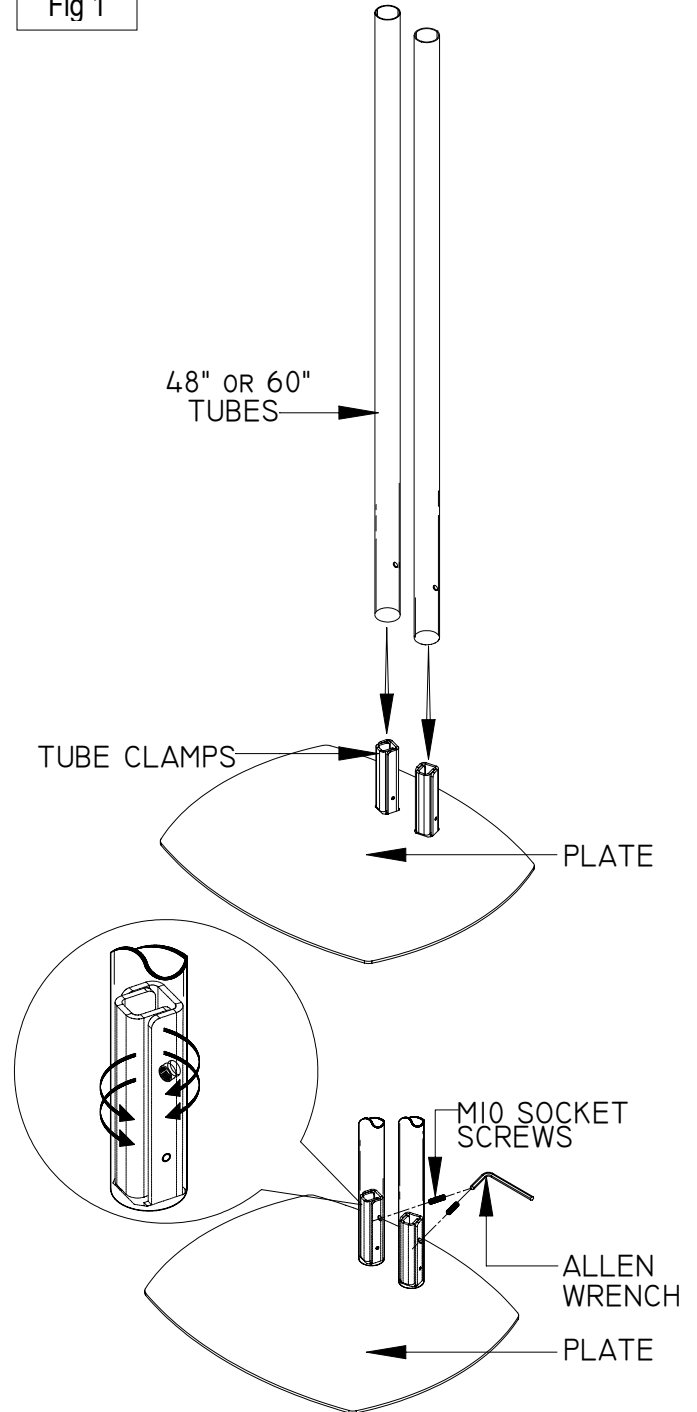

Hardware

Qty	Description
4	M10 Bolts and flat washers
1	M6 x 12 (mm) Phillip screws (optional shelves)
1	5/32" Allen wrench
1	M10 Allen wrench
2	M8 x 10 (mm) Socket screws

WARNING!

The wall, floor or ceiling should be capable of supporting a weight of at least five (5) times the plasma's weight. If it cannot, the ceiling must be reinforced. Proper installation procedure by qualified personnel as outlined in the installation instructions must be adhered to. Failure to do so could result in serious personal injury.

Step 2

Install the PP-ADAP (stand adapter) through the top of the tubes and secure it to your desired height with the two (2) M8 Allen screws found on the back of the adapter. Use the 5/32" Allen wrench (supplied). See fig 2.

Fig 2

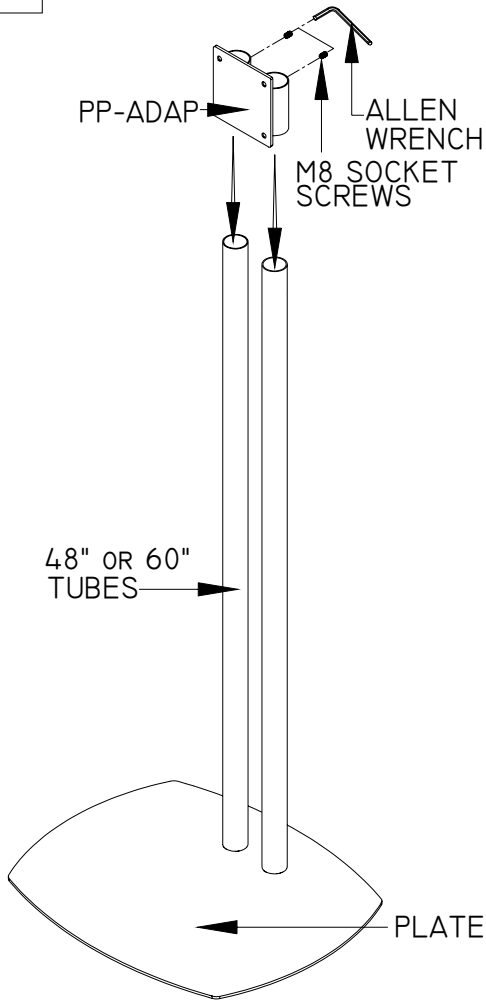

Step 3

NOTE: The back plate will vary depending on the system ordered. There are two (2) different systems for this stand PSM series and CTM series.

CAUTION: Arrow must be pointing up prior to installation.

Secure the following plates to the secured PP-ADAP on the tubes. For the PDB-UWFB (PSM-Series) secure the back plate to the four (4) threaded mounting points found on the PP-ADAP with the four (4) M10 bolts and flat washers (supplied).

For the CTM-Back plate (CTM-Series) secure the back plate to the four (4) threaded mounting points found on the PP-ADAP with the four (4) M10 bolts and flat washers (supplied). See fig 3.

Fig 3

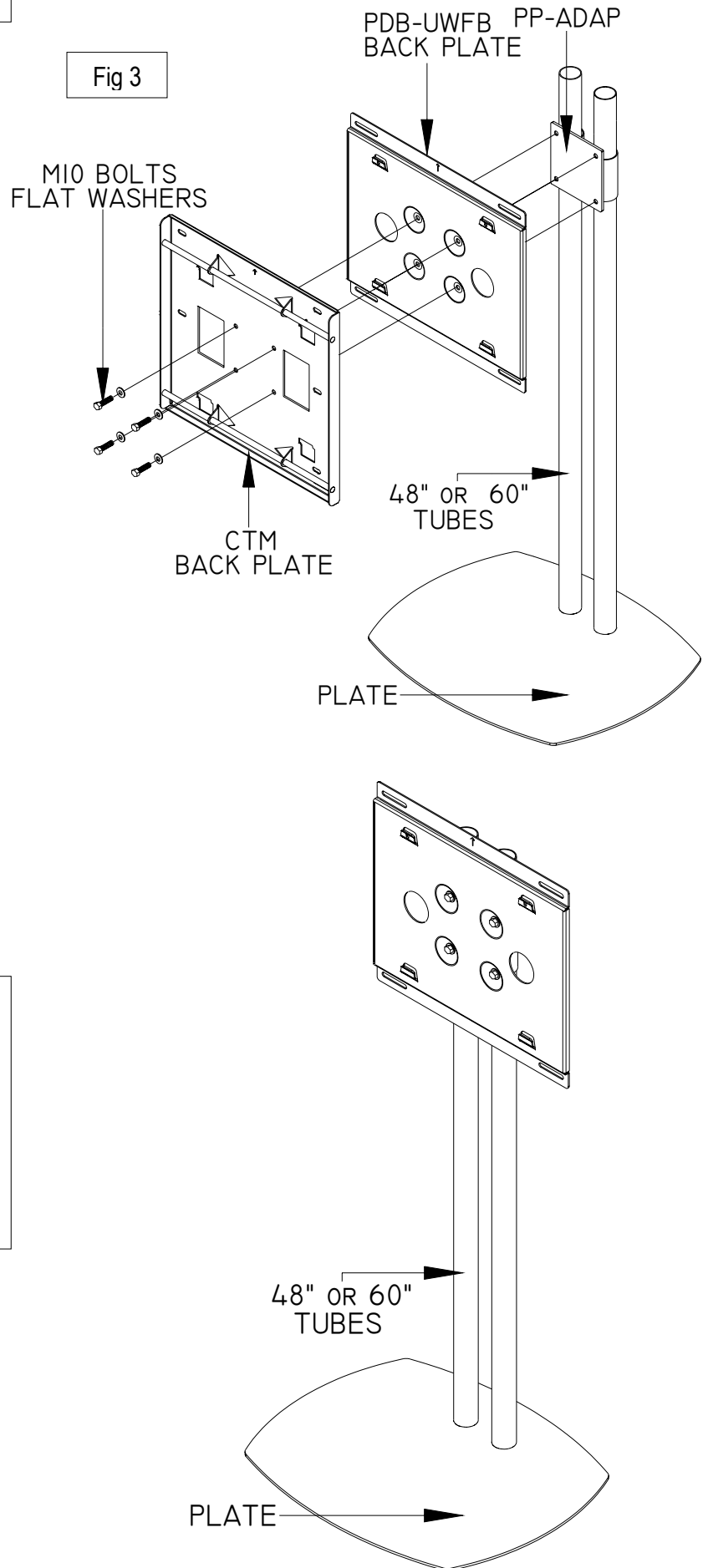

Step 4

CAUTION: The plasma display is vary heavy two people are required to lift the plasma and secure it to the stand.

NOTE: To install the PSM-series or CTM-series mounting brackets to the plasma display refer to its installation instructions.

PSM-Series: Raise the plasma display with the mounting bracket secured to the plasma and insert the four (4) tab openings from the PSM mount to the four (4) receiving tabs found on the PDB-UWFB back plate push the to Slide the plasma down, right and down again to lock the mounts together. Make sure all tab openings are interlocked with the receiving tabs before letting go of the plasma. Secure the brackets with the two (2) M6 x 12 (mm) Phillip screws (supplied).

CTM-Series: Raise the plasma display with the left and right brackets secured to the plasma and insert the bottom and top hooks from the mounting arms to the top and bottom rods found on the CTM back plate. Secure the mounting arms with the two (2) M6 x 12 knurl knobs (supplied). See fig 4.

Fig 4

PSM-Series

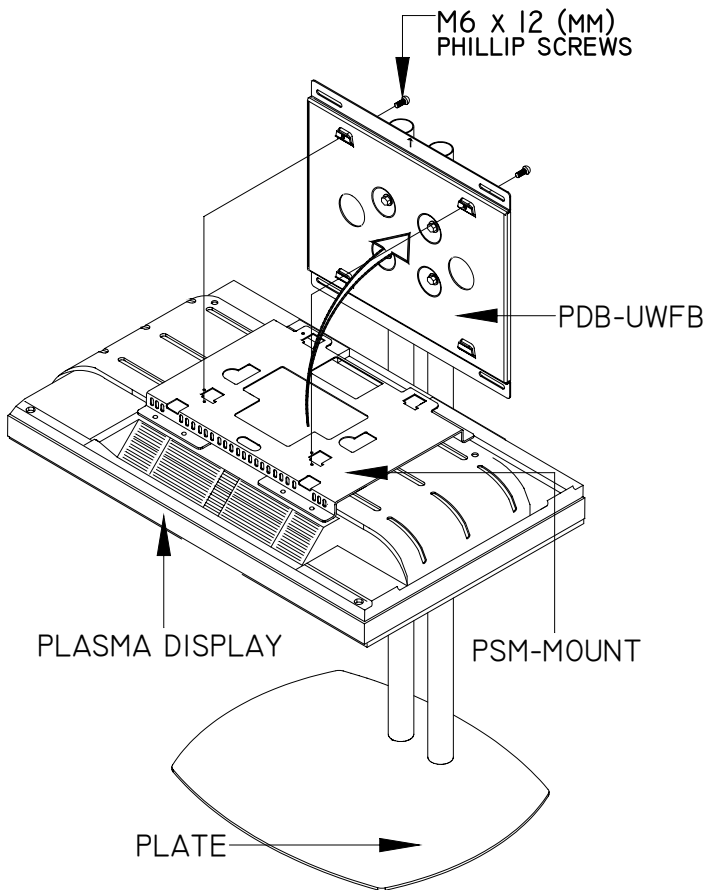

CTM-Series

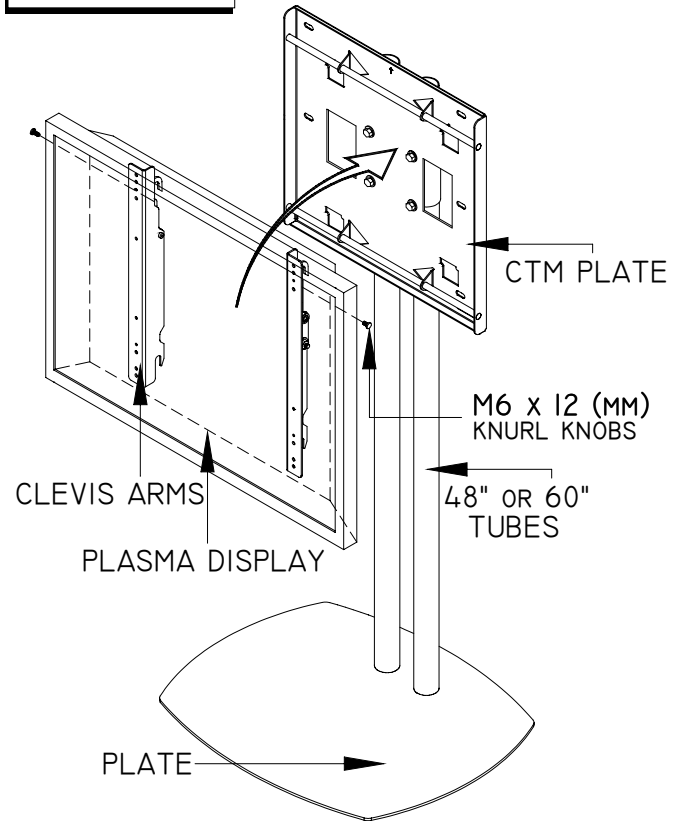

Step 5

NOTE: Do not install the shelf before the PP-ADAP. The shelf must be added after the plasma has been installed to the stand.

Install the shelf to the poles in a vertical position bypassing the poles then set the shelf back to horizontal position. Install the shelf adapter as shown and secure the M6 x 12 (mm) Phillip screw. Set the desired height. The shelf adapter will secure the shelf to the poles. See fig 5

CAUTION: Do not over tighten the M6 x 12 (mm) Phillip screw to the shelf.

Fig 5

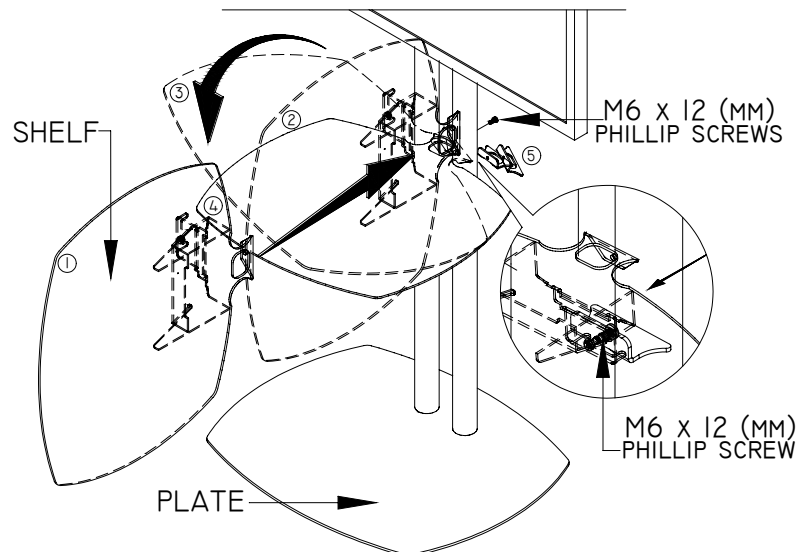

Installing the (optional) covers

Step 6

Install the magnetic cover to the poles to hide all cables. See fig 6

Note: Make sure to recheck all hardware for proper tightness and security.

Fig 6

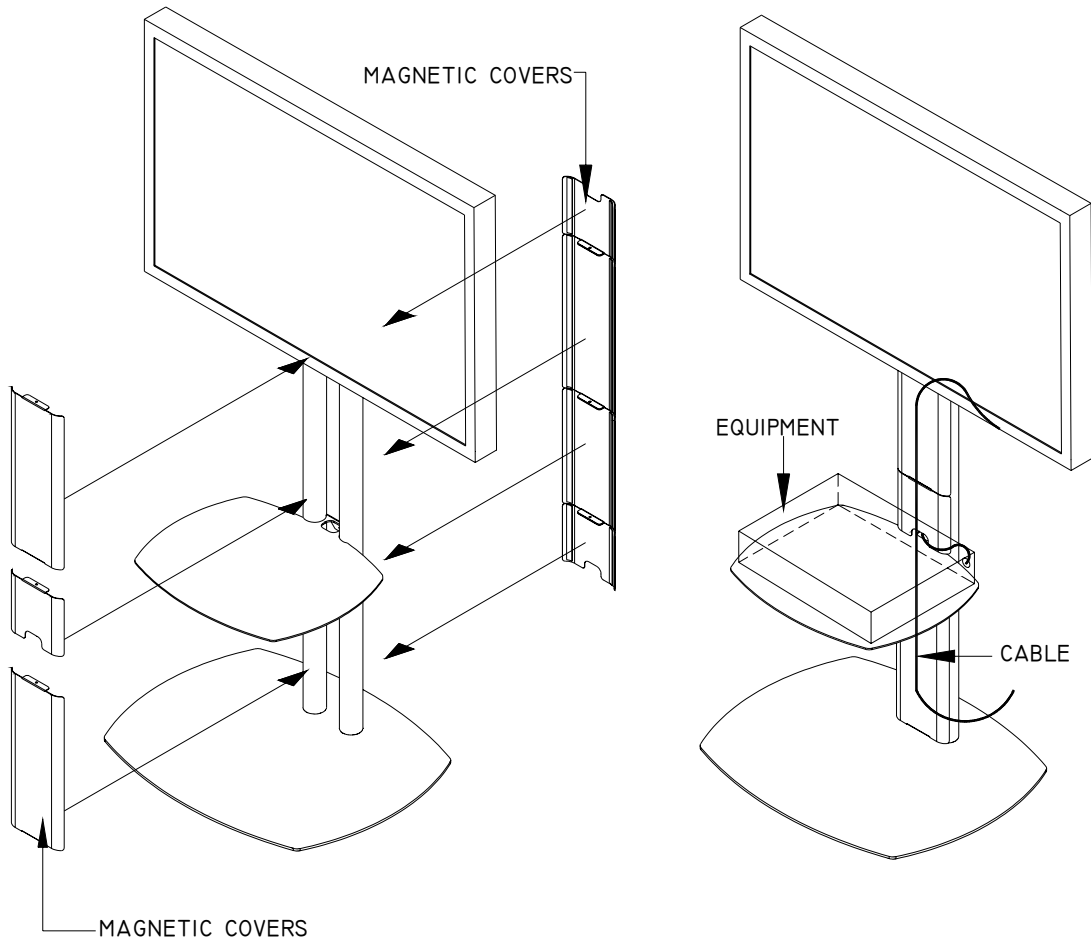

(Optional) PLINTH STAND CABLE COVERS

The covers vary depending on the stand system

PSD-PL48"

No Shelf: (3) 16" (1) 12" (1) 6"

1 Shelf: (3) 16" (1) 12" (3) 6"

2 Shelves: (2) 16" (1) 12" (4) 6"

PSD-PL60"

No Shelf: (3) 16" (3) 12" (1) 6"

1 Shelf: (3) 16" (3) 12" (3) 6"

2 Shelves: (2) 16" (3) 12" (4) 6"