

## © Ergonomic Guidelines

### Recommended Mounting Position

- When mounting the Spacedec Acrobat Swing Arm, ensure the correct focal distance can be achieved for ultimate visual comfort (Refer to Recommended Viewing Distance / Height below)

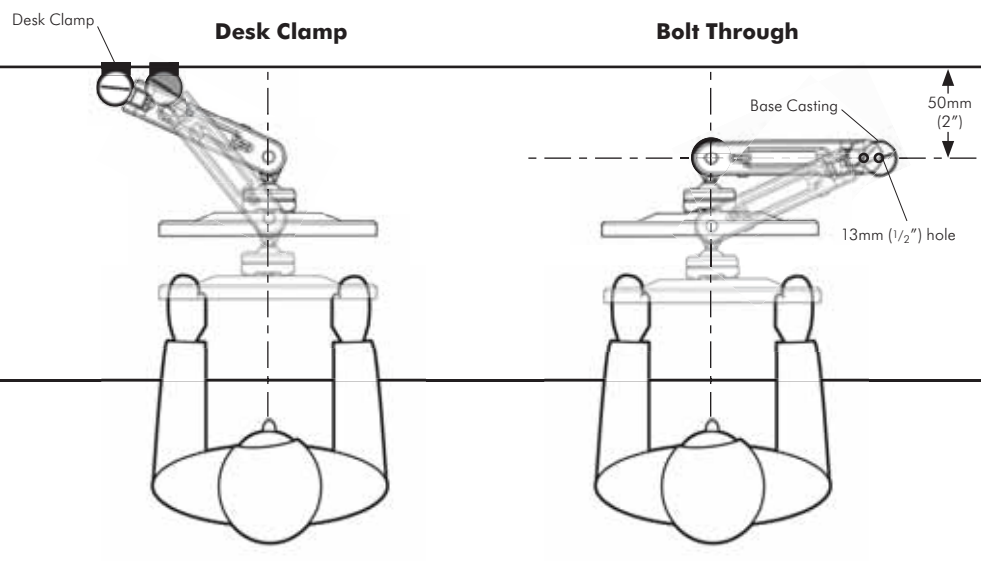

### Recommended Viewing Distance / Height

- Ergonomists recommend that the optimal position of your screen should be slightly below eye level. When looking at the screen's centre the user should have a downward visual angle of approximately 10°-20°. As a guide, the height (h) of your display should approximately be as follows:

- Tall Male (Max): 560mm (22")
- Tall Female (Max): 520mm (20½")
- Short Male (Min): 368mm (14½")
- Short Female (Min): 356mm (14")

- For visual comfort, a viewing distance (d) between 500mm (19½") to 750mm (29½") is recommended.

- Angular adjustments to reduce reflection on your monitor should range between 5° forward tilt to 15° backward tilt.

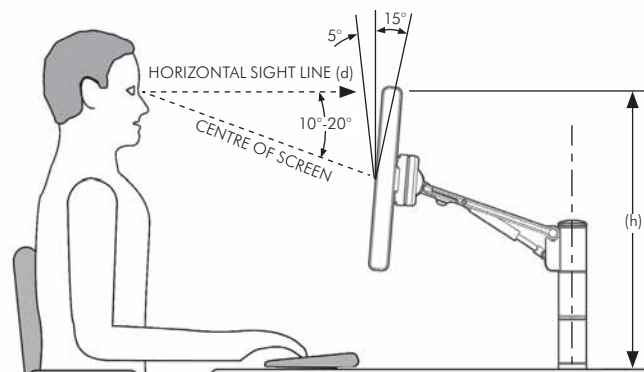

## Ⓜ Adjusting the Display

The Acrobat Swing Arm comes factory set to support 6kg displays. Adjust the arm to suit the weight of your display as shown in the following steps:

### H.1. Adjusting the Ball Joint Resistance

Depending on the weight of the monitor, it may be necessary to make adjustments to the Ball Joint Mechanism. If the monitor doesn't hold its position or is too resistant, adjust the four tension screws located around the Ball Joint (see diagram on the right) using the supplied 2.5mm Allen Key.

Check the display, and then adjust again if necessary.

**NOTE: Be sure to adjust screws evenly.**

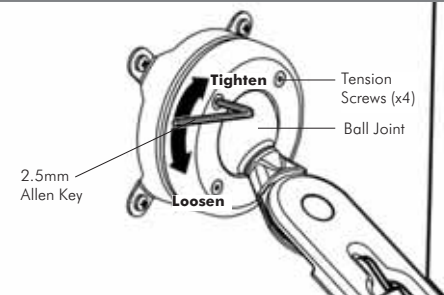

### H.2. Adjusting the Pivot Head Resistance

It is possible to control the amount of resistance in the Pivot Head to suit your display.

To increase the resistance of the Pivot Head to suit heavier displays, use the 5mm Allen Key supplied in the Desk Clamp Box to tighten the interscrew in a clockwise direction.

To decrease the resistance of the Pivot Head to suit lighter displays, loosen the interscrew in an anti-clockwise direction.

**NOTE: It is recommended the Pivot Head be left at the factory setting for best performance.**

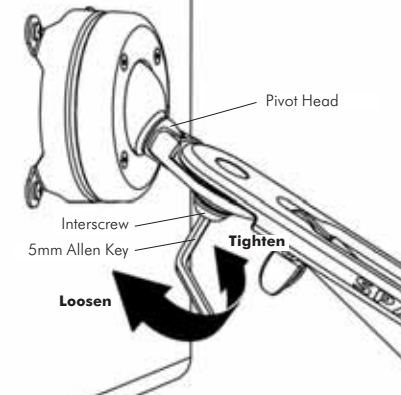

### H.3. Adjusting the Swing Arm/Gas Strut Resistance

**H.3.1.** Depending on the weight of the monitor, it may be necessary to adjust the arm. This can be done by using the 5mm Allen Key supplied in the Desk Clamp Box.

**H.3.2.** If the arm tends to automatically rise or fall when the display is attached, it will be necessary to make small adjustments to the gas strut. (see diagram on the right)

**H.3.3.** If the arm tends to rise, the gas strut position should be raised. If the arm tends to fall, the gas strut position should be lowered.

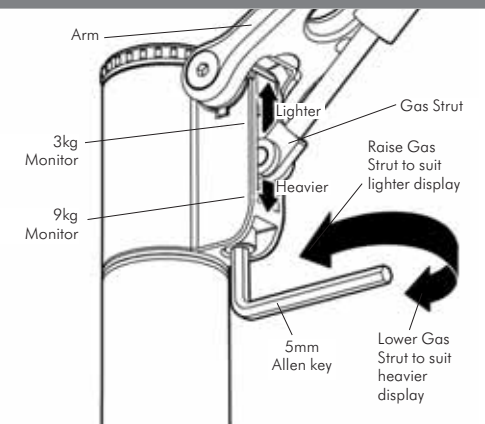

**Installation Complete**



As LCD Manufacturers are constantly releasing new monitor models, Atdec does not accept responsibility if the mounting hole pattern does not comply with the international VESA standards. Due to continuing product development, the manufacturer reserves the right to alter specifications without notice. Published: 10.02.12



# Installation Instructions

## SPACEDEC ACROBAT

### SD-SA-DK / SWING ARM

## Component Checklist

### Single Arm

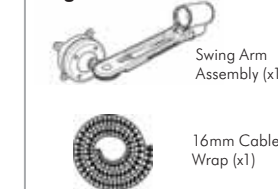

### Tube Assembly (x1)

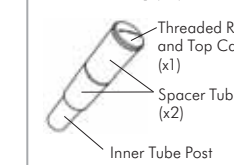

### Bits Box

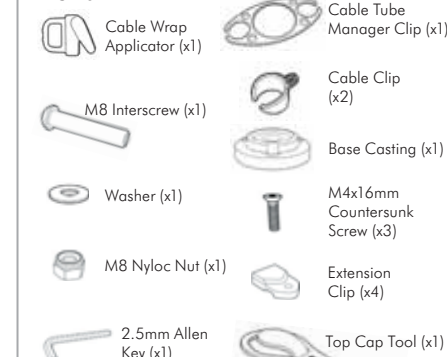

### Desk Clamp Box

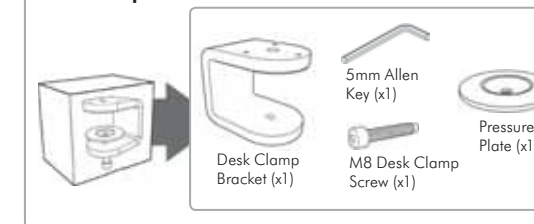

## A Component Checklist

Check you have received all parts against the Component Checklist above.

## B Assembling the Arm

### B.1. Disassemble the Tube Assembly

You will need to disassemble the Tube Assembly before assembling the Swing Arm

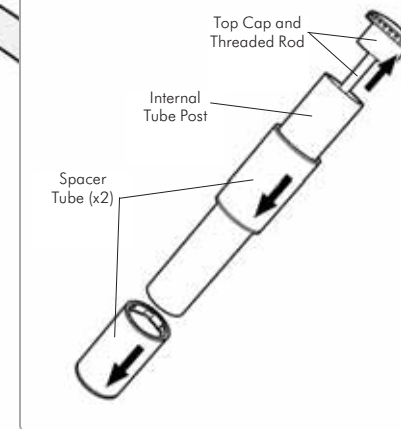

### B.2. Assemble the Swing Arm

Assemble the Swing Arm as shown:

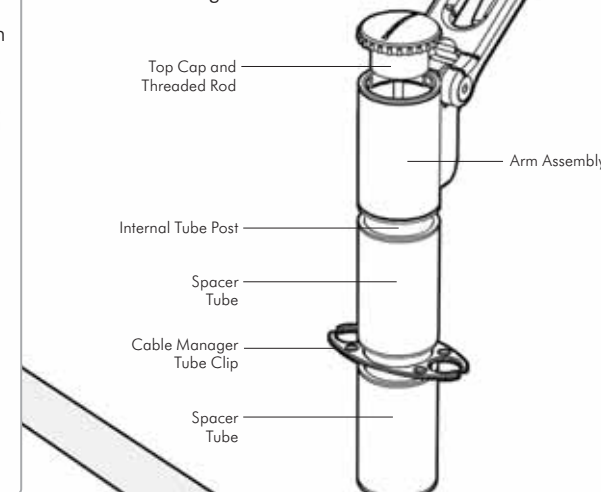

**C Mounting Options**

There are two Mounting Options: **Desk Clamp** and **Bolt Through**  
 To use the **Desk Clamp** (Suits desktop thicknesses of 12mm-38mm [1/2"-1 1/2"] follow the Desk Clamp instructions at **C.1.** To use the **Bolt Through** system (Suits desktop thicknesses of 12mm-40mm [1/2"-1 1/2"] follow the Bolt Through instructions at **C.2.**

**C.1. Desk Clamp**

**C.1.1. Assemble the Desk Clamp**

To assemble the Desk Clamp Assembly, first place the M8 Nyloc Nut inside the Base Casting with the Plastic Ring facing down, then screw the Base Casting on to the Desk Clamp Bracket using the M4x16mm Countersunk screws.

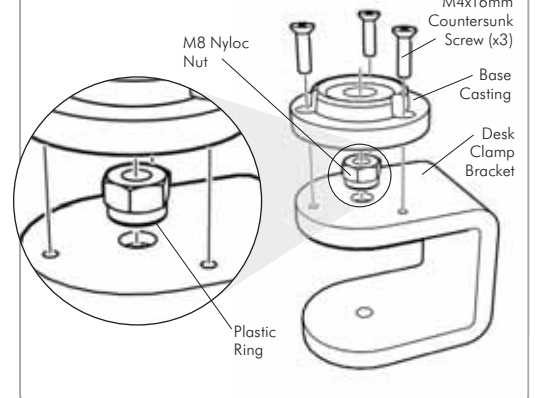

**C.1.2. Attaching the Desk Clamp**

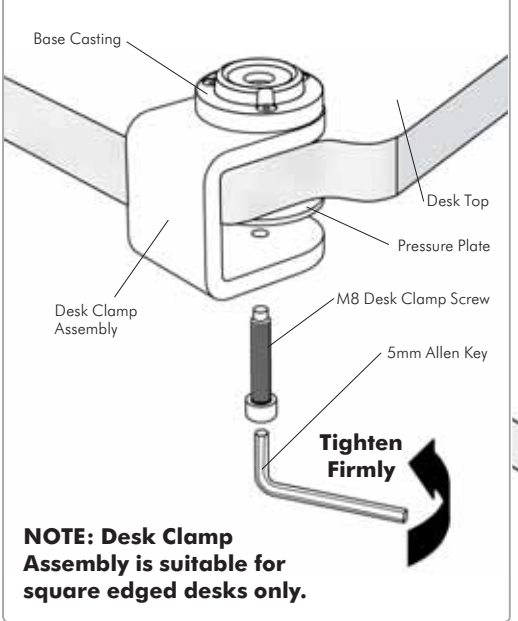

**DESK CLAMP ADJUSTMENT RANGE**

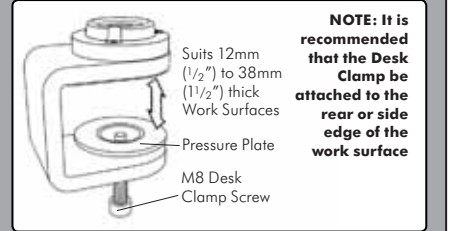

Adjust the Desk Clamp to suit your desk thickness by turning the M8 Desk Clamp Screw with the supplied 5mm Allen Key

**C.1.3. Attaching the Swing Arm Post**

Use the Top Cap Tool to tighten the Threaded Rod into the Base Casting as shown below:

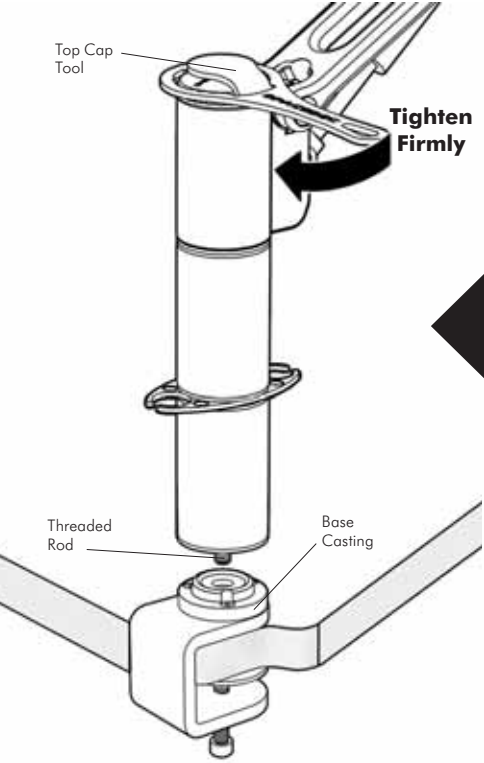

**C.2. Bolt Through**

**C.2.1. Drill Mounting Hole**

Drill a 13mm (1/2") hole in your work surface at the desired location for your arm.

**C.2.2. Install as shown**

Insert the M8 Interscrew up through the hole in the work surface.

Using both hands, secure the M8 Interscrew with the 5mm Allen Key supplied in the Desk Clamp Box and use the other hand to tighten the Threaded Rod into the Interscrew with the supplied Top Cap Tool.

**Touchboards**  
 205 Westwood Ave, Long Branch, NJ 07740  
 Phone: 866-94 BOARDS (26273) / (732)-222-1511  
 Fax: (732)-222-7088 | E-mail: sales@touchboards.com

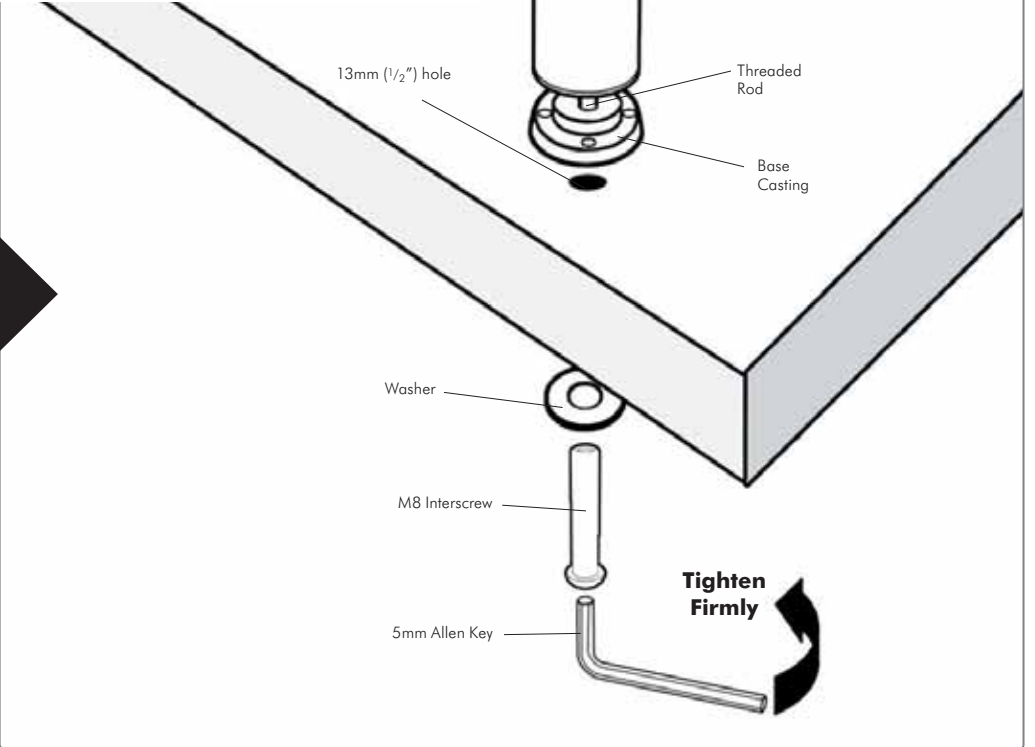

**D Attaching the Display**

Direct Mount Configuration

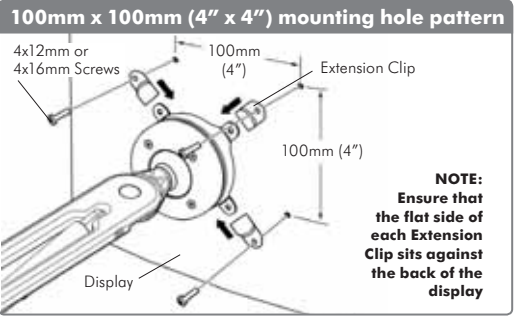
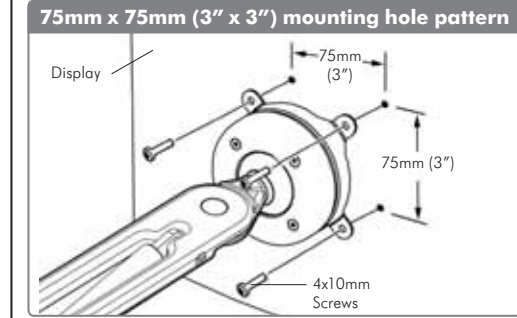

**E Installing Cable Management**

- E.1.** Push the two supplied Cable Clips into the holes on the underside of the arm as shown in diagram
- E.2.** Feed the cables into the Cable Wrap Applicator.
- E.3.** Insert the Cable Wrap Applicator into the Cable Wrap as shown.
- E.4.** Squeeze the nose of the Applicator and place inside the Cable Wrap ensuring that the opening edges of the Cable Wrap face towards the nose of the applicator as shown in diagram.

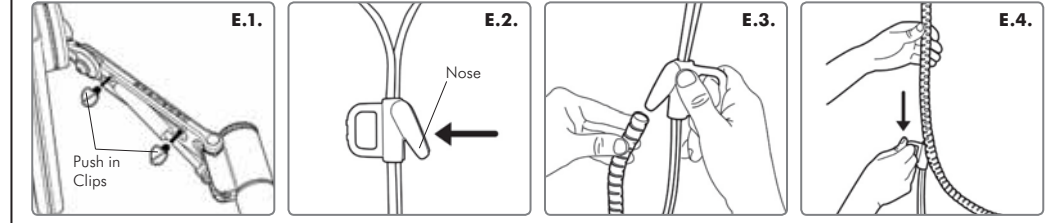

**F Attaching the Cable Wrap to the Arm**

- F.1.** Position the display at its highest possible position to ensure that there is sufficient cabling at the end of the arm so the cables are not stretched or pulled out when the display is moved.
- F.2.** Clip the cable wrap into the Cable Tube Manager Clips as shown in diagram.

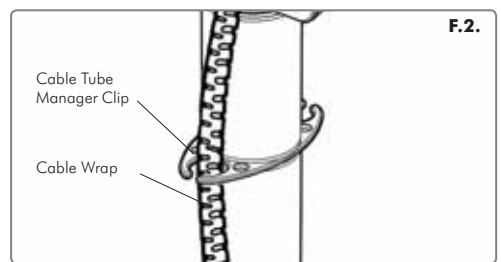
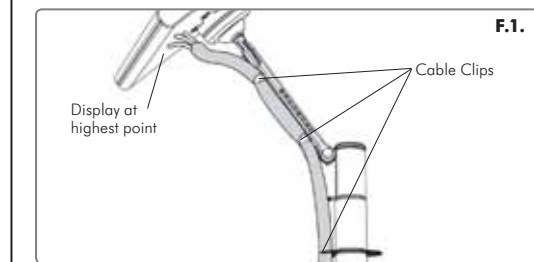

**BEFORE PROCEEDING TO THE NEXT STEP PLEASE NOTE:**  
 Swing Arm will only work when a display is properly installed.  
**DO NOT** adjust tension screws or gas strut until your display has been attached.