

VADDIO™ WALLVIEW™ CCU HD-19 HD-SDI

High Definition PTZ Camera Featuring the Quick-Connect™ CCU Interface and the EZIM HD-SDI Slot Card



205 Westwood Ave, Long Branch, NJ 07740
Phone: 866-94 BOARDS (26273) / (732)-222-1511
Fax: (732)-222-7088 | E-mail: sales@touchboards.com



Arctic White Version
Part Number 999-6948-000AW (North America)
Part Number 999-6948-001AW (International)



Black Version
Part Number 999-6948-000 (North America)
Part Number 999-6948-001 (International)



EZIM HD-SDI Slot Card for HD-19

Quick-Connect CCU Interface for HD-19



Inside Front Cover - Blank

WallVIEW CCU HD-19 Overview:



The WallVIEW CCU HD-19 HD camera, Quick-Connect CCU and EZCamera™ Cat-5e cabling system using HSDS™, delivers a system that allows for easy installation and integration. The HD-19 camera is built around a 1/3-type Exmor high-speed CMOS image sensor with a total of 1.3 Megapixels and a 19X optical zoom lens, making it the ideal choice for a wide range of HD video applications.

Because the camera module is built around a new, high speed CMOS image sensor with an increased pixel aperture size, high frame rate, high signal to noise ratio, using the column-parallel A/D conversion method, the resolution, saturation and the sensitivity of the sensor is increased. The HD-19 achieves improved picture quality even in low light environments requiring a minimum illumination rated at an astonishing 0.7 LUX (F1.6 - 50IRE).



The HD-19 is paired with the Quick-Connect CCU Interface and EZIM CCU Slot Card, which provides power, video and control to the camera up to 500' (152.4m) over three (3) Cat-5e cables. The Quick-Connect CCU functions allow users to control a variety of image controls built into the camera, including iris, red and blue gain, pedestal, knee, chroma, SmartShot™ and overall gain. The CCU also has three (3) preset scenes available for time of day or other interesting lighting conditions.

The WallVIEW CCU HD-19 is an exceptional camera system for integration projects, since no power supply is required at the camera location. Use the WallVIEW CCU HD-19 for high definition camera applications, such as houses of worship, corporate boardrooms, live event production and distance-learning.

Intended Use:

Before operating the device, please read the entire manual thoroughly. The system was designed, built and tested for use indoors, and with the provided power supply and cabling. The use of a power supply other than the one provided or outdoor operation has not been tested and could damage the device and/or create a potentially unsafe operating condition.

Important Safeguards:

Read and understand all instructions before using. Do not operate any device if it has been dropped or damaged. In this case, a Vaddio technician must examine the product before operating. To reduce the risk of electric shock, do not immerse in water or other liquids and avoid extremely humid conditions.



Use only the power supply provided with the system. Use of any unauthorized power supply will void any and all warranties.



Please do not use "pass-thru" type RJ-45 connectors. These pass-thru type connectors do not work well for professional installations and can be the cause of intermittent connections which can result in the RS-232 control line failing and locking up, and/or compromising the HSDS™ signals. For best results please use standard RJ-45 connectors and test all cables for proper pin-outs prior to use and connection to Vaddio product.

Save These Instructions:

The information contained in this manual will help you install and operate your product. If these instructions are misplaced, Vaddio keeps copies of Specifications, Installation and User Guides and most pertinent product drawings for the Vaddio product line on the Vaddio website. These documents can be downloaded from www.vaddio.com free of charge.

UNPACKING:

Carefully remove the device and all of the parts from the packaging. Unpack and identify the following parts for 999-6948-000:

- One (1) ClearVIEW HD-19 HD Camera
 - One (1) Vaddio IR Remote Commander
 - One (1) Quick-Connect CCU Interface
 - One (1) EZIM HD-SDI Slot Card
 - One (1) 36 VDC, 2.78A Power Rite™ Switching Power Supply
 - One (1) 998-1001-232 EZCamera Control Adapter (for control systems)
 - One (1) Thin Profile Wall Mount with Mounting Hardware
 - One (1) AC Cord Set for North America
 - Documentation
- (Note: The 999-6948-001 Int'l Version includes the Euro and UK power cables)

ClearVIEW HD-19 PTZ Camera, Front View with Feature Call-outs:



1) Zoom Lens and Image Sensor:

The 19X optical zoom lens is built around a 1/3-Type, high-speed, progressive scan CMOS image sensor with a total of 1.3 Megapixels for precise HD video image acquisition.

2) Red Tally Light:

A red tally light is illuminated when the camera receives a VISCA command from an external control system.

3) IR Sensors:

IR sensors are built into the front of the ClearVIEW HD-19 to receive IR signals from the IR remote control supplied with the camera.

4) Blue Power Light:

A Vaddio blue power light is illuminated when the camera is turned on.

Compatible Switchers and Joystick Controllers:



ProductionVIEW™ HD MV
(999-5625-000)



AutoPresenter
(999-5675-000)



Precision Camera Controller
(999-5700-000)

ClearVIEW HD-19 PTZ Camera, Rear View with Feature Call-outs:



5) RS-232 IN & IR Out: The RS-232 accepts modified VISCA protocol for camera control, as well as transmits IR signaling received by the IR receivers, which can be transmitted to third party devices.

6) Dip Switch Settings: Settings for IR remote, baud rate, SD output format, and image flip can be configured on these switches. See page 5 for additional information on switch settings.

7) HD Video Select: A rotary switch allows the user to choose the component HD output video resolution and format. See page 6 for additional information on switch settings.

8) 12 VDC Input: Power input for the standard, ClearVIEW HD-19 camera power supply.

9) YPbPr Output: Component HD video is fed through the DB-15 connector. YPbPr and Composite signals are simultaneous. This is an HD camera and the SD signals are down converted and are really not the sweet spot of this camera.

9) Composite Video (CVBS) Output: The CVBS output feeds out SD video signals and is configurable with the dip switches to choose between 480i/NTSC or 576i/PAL in 4:3 formats. Squeeze and letterbox modes are also available (see dipswitches 6&7).

11) EZ Power/Video Port: This RJ-45 connector is only used with the Quick-Connect SR Interface and the Quick-Connect DVI-D/HDMI SR Interface to supply power and return HSDS video from the camera.

12) Slot for Optional Cards: Optional slot cards can be plugged into the ClearVIEW HD-19 camera. For this package, the HD-SDI Slot Card is included and shown installed above. The HD-SDI Slot Card uses a RJ-45 for a 36V power jack and two (2) HD-SDI outputs. See *Important Safeguard below*.

IMPORTANT SAFEGUARD



Do not insert or remove the EZIM HD-SDI Slot Card into an HD-19 Camera when the camera is powered ON. Detach all power connectors before installing or removing the EZIM HD-SDI Slot Card.

Quick-Connect CCU for HD-19, Front Panel Controls (left to right):



Tally Light:

The blue LED tally light on the front panel is tied to the tally contacts on the rear panel allowing the user to easily track which camera interface is being used in a multi-camera system by supplying a simple contact closure.

LCD Display:

Backlit (blue) display indicates which parameter (iris, detail, etc.) is being adjusted. When a rotary encoder is moved, the name of the control being adjusted and the value of that assigned parameter will be displayed.

Quick-Connect CCU Controls (left to right - magnified):



Scenes A, B & C:

Three camera adjustment scenes (A, B & C) can be stored into microprocessor memory. When lit (backlit blue SPDT Button), the scene is activated. To store a scene, the user adjusts the controls and touches and holds the scene button down until the button blinks.

Detail: The Detail control sharpens or softens objects in the frame. This control works well to sharpen text.

Red & Blue Gain Controls: The Red and Blue Gain encoders adjust the red and blue gain of the signal when AWB is disengaged.

AWB: The Automatic White Balance controls/adjusts the color levels automatically when engaged. Turn off AWB to manually adjust the Red and Blue levels, as well as Red, Green and Blue Enhance.

OPWB: One Push White Balance is not operable in this release

Gamma, Chroma and Brightness Control:

Gamma adjusts the overall brightness of an image. Chroma controls the color of the image being acquired without affecting brightness. The brightness control governs the overall brightness of the image.

SHIFT: Pressing Shift illuminates the button and changes the Gamma, Chroma and Brightness Control to Digital Image Stabilization, Shutter Control and Noise reduction. **Digital Image stabilization** works well if the camera is hand-held or the surface where the camera is mounted has vibration (front of a church balcony). **NOTE:** When using a joystick for control of the camera, leave image stabilization off because the subsampled window if the video image will cause delay and is not going to allow an operator to be very precise with the camera movement and joystick. **Shutter** adjustments are 1/30 to 1/500. For most applications 1/60 will work fine. **Noise Reduction** can be on or off and will help reduce the noise produced by sub optimum conditions.

Auto Iris: The Auto Iris mode automatically adjusts the iris and gain of the camera. To manually adjust the iris or gain, turn off this control. With auto Iris engage, the SmartShot (AGC Gain Limit) can be set to off, low, med, and high. SmartShot limits the ACG Gain to avoid poor image reproduction in suspect lighting conditions).

Manual Iris: The Manual Iris control allows the user to set the iris manual to one of the settings available.

Gain: The Gain control boosts the signal level when the iris is open all the way, and there is not enough lighting available. To manually adjust the Gain, Auto Iris must be off.

Quick Connect CCU Rear Panel Connections and Controls (left to right)



Power Supply Input:

36V 2.78 Amp power supply on a 5.5mm OD x 2.5mm ID connector.

Power on RJ-45:

Power is provided on a Cat-5e cable to the EZIM CCU Slot Card. Power is on all 4-pr and is connected to the 36VDC RJ-45 on the EZIM CCU Slot Card.

RS-232 IN on RJ-45:

RS-232 IN from ProductionVIEW or PTZ controller RS-232 port. Daisy Chain control is not supported.

RS-232 OUT / G/L Out on RJ-45:

The RS-232 OUT is connected to the HD-19 RS-232 RJ-45 jack. The HD-19 camera does not support GENLOCK.

Tally on 2-pin Phoenix type connector:

Contact Closure lights a Vaddio blue LED on front panel allowing indication of which CCU/camera combination is active in a multi-camera/CCU installation. A tally command will also be sent to the HD-19 camera to illuminate the red LED on the camera's base.

G/L Input on BNC-F:

This option is not used with the HD-19 camera.

Camera Feature Switches:

The Quick-Connect CCU has an 8-position dip switch on the rear panel. For the HD-19, all these switches should be set to the down position.

*Y-Gain:

Adjusts Y-Gain and allows the user to fine tune the video signal especially over longer cable lengths. Adjust to system requirements (100 IRE on waveform analyzer). *The WallVIEW CCU HD-19 HD-SDI does not typically use this adjustment.*

*Distance:

Distance adjustments for Cat-5e cable (<100', 200', 300', 400'+) which, equalizes the length of the twisted pairs for improved video performance. *The WallVIEW CCU HD-19 HD-SDI does not typically use this adjustment.*

*Video Outputs:

When using the HD-SDI EZIM Slot Card, the video connectors (YPbPr, Y/C and Composite are no longer active on the back of the CCU).



However, if a Cat-5e cable from the VIDEO port on the back of the CCU is connected to the EZ POWER HD VIDEO RJ-45 port on the camera, differential HSDS YPbPr signals are sent from the camera to the CCU allowing for a YPbPr output at the same resolution as the HD-SDI signal, which can be used for other applications. Please note that the same image controls will be applied to the HD-SDI and YPbPr signals.

Video RJ-45

This jack is not typically used with the WallVIEW CCU HD-19 HD-SDI. However, interesting configurations using the HD-SDI and analog video are possible since all the outputs of the camera remain live.

*Note: Typically Y-Gain, Distance and the Video outputs of the CCU will go unused when the HD-SDI Slot Card is in the camera, unless a 3rd Cat-5e cable is used in the application note above.

EZIM HD-SDI Slot Card

Using only the most advanced and leading edge components available today, the EZIM HD-SDI produces remarkable picture quality and is capable of 3Gb/s single link HD-SDI. Currently, the EZIM HD-SDI coupled with the HD-19 camera can output up to 1080p/60, has been tested and is compatible with the single link 3Gb/s inputs of the Vaddio ProductionVIEW HD-SDI Seamless Video Switcher and Camera Controller.

The HD-19 is very flexible and supports both 1080i/59.94 and 720p/59.94 drop frame video (DF) for broadcast applications and 1080i/60 and 720p/60 non-drop frame video (NDF) for videoconferencing and A/V applications (see page 10 for resolution switch settings).

Anatomy of the Vaddio EZIM HD-SDI Slot Card:

- 1) Two (2) HD-SDI/SDI Outputs on BNC
 - a. Carrier Class, Gold Finish Body and Contacts, Circuit Board Edge Mount
- 2) One (1) RJ-45 Jack 36VDC used to Power HD-19 Camera and Card with the Quick-Connect CCU
- 3) Two (2) Captive, Spring Loaded, Retractable Thumb Screws

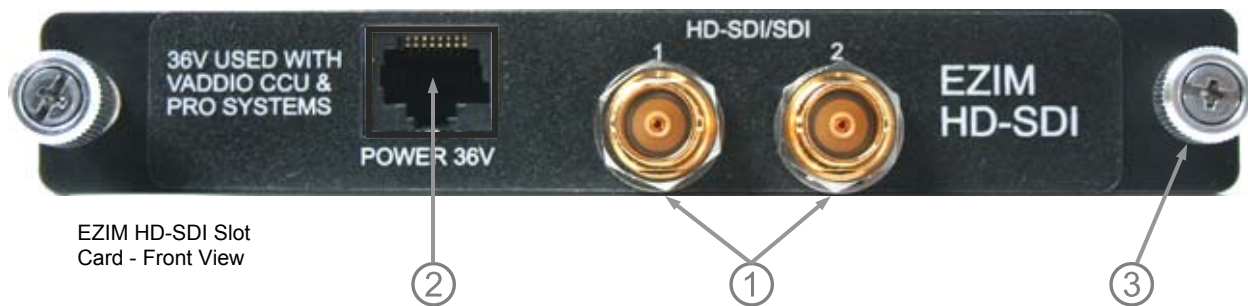

EZIM HD-SDI Slot Card - Front View

- 4) 24-Pin Self Guiding Blind Mating Interface Connector
- 5) Power Module (Regulator) provides power to Camera and Slot Card
- 6) HD-SDI transmitter, generating a SMPTE 292M compliant serial digital output signal with integrated low noise VCO and integrated cable driver

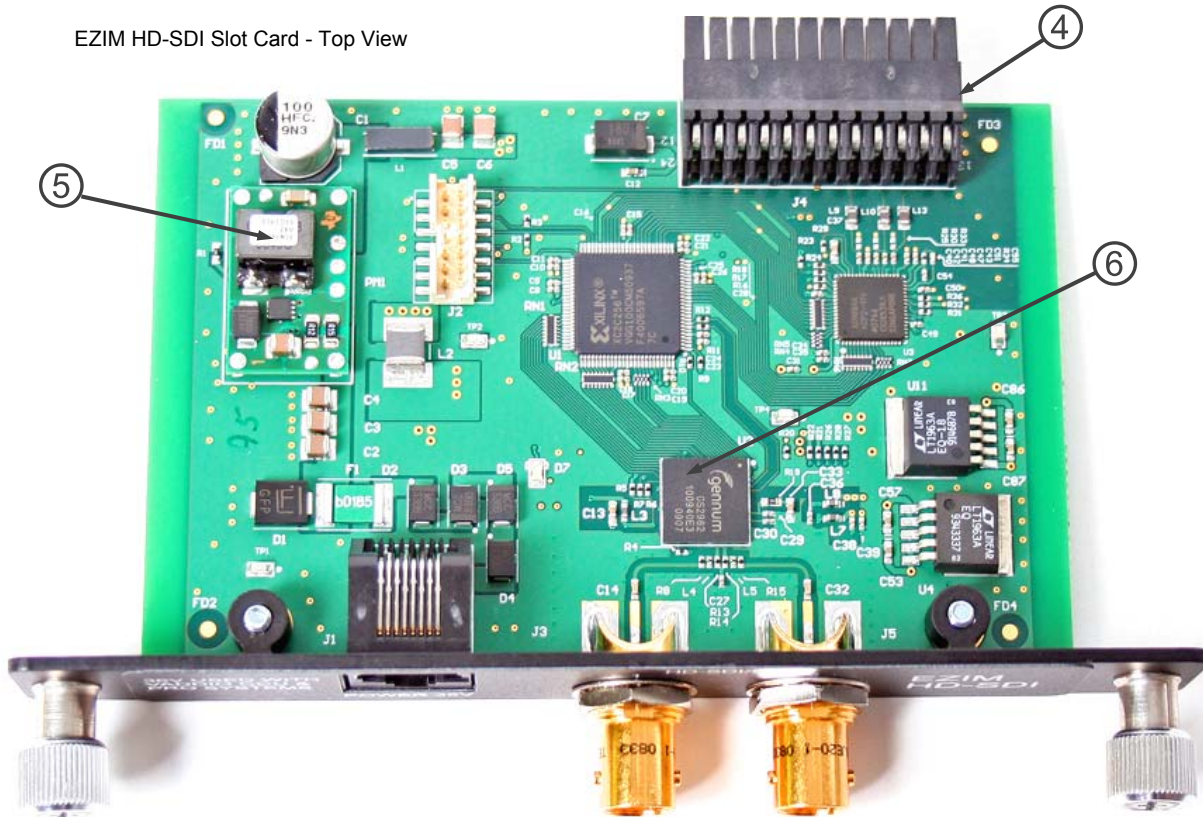

EZIM HD-SDI Slot Card - Top View

Installing the EZIM HD-SDI Slot Card:

- The Slot Card will be packed separately. **To install the EZIM HD-SDI Slot Card, remove all power connections** and be certain that the HD-19 camera is not powered up before attempting to install the EZIM HD-SDI Slot Card. Remove the blank plate (1) that covers the card slot opening. Retain the blank panel as needed in case the Slot Card is ever removed.



Rear View of HD-19 with Blank Plate Shown



Please disconnect camera from power before inserting or removing the EZIM HD-SDI Slot Card.

- Carefully slide the EZIM HD-SDI Slot Card into the HD-19 camera base and let the self-mating connectors engage. The camera base is notched on either side of the card slot to aid in alignment. Push the Slot Card in completely.
- When the Slot Card is fully seated, tighten the retractable spring loaded captive screws (4). Do not force or cross-tread the captive screws. Slowly tighten both of the screws at the same time to avoid any undesirable and/or dastardly threading incidents.

Note: The video outputs on the camera body (SD and HD YPbPr) remain live and allow for simultaneous output along with the HD-SDI Outputs.

Slot Card Dimensions:

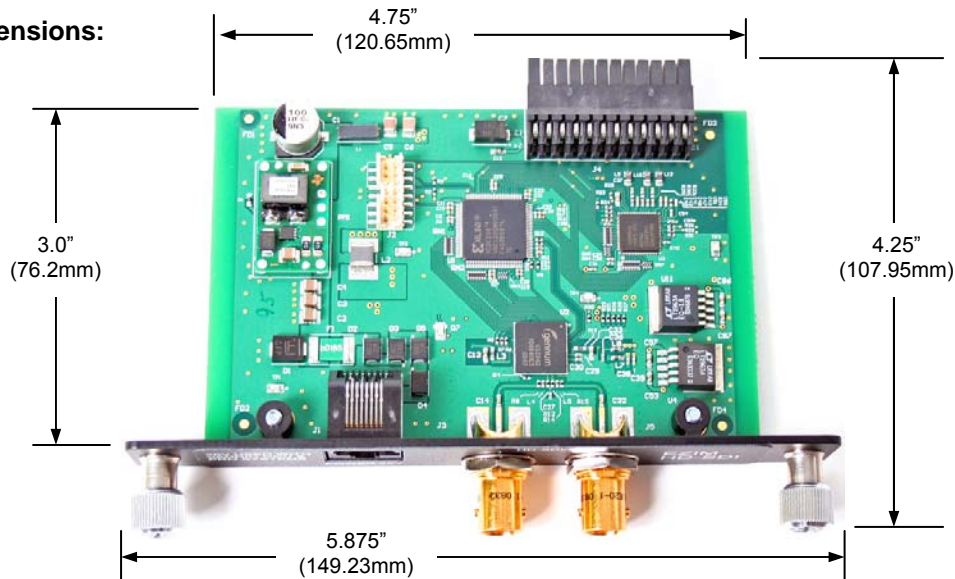

HD-SDI/SDI Cable Distances: Using the ProductionVIEW HD-SDI Console and the HD-18 HD-SDI Slot Card, expected HD-SDI/SDI cable distances are approximately:

Resolutions:	SMPTE STD	Cable Distances*
720p	SMPTE 292M	Max. Length: 754.543 ft. (230m)
1080i 1080p/29.97/25 Hz	SMPTE 292M	Max. Length: 754.543 ft. (230m)
1080p**	SMPTE 424M	Max. Length: 459.287 ft. (140m) 1080p/60/59.94/50Hz - 3Gb/s compliant
480i	SMPTE 259M	Max. Length: 820.179 ft. (250m)
576i	SMPTE 259M	Max. Length: 820.179 ft. (250m)

*Distances are approximate and based on using Belden 1694A coax cable. Results may vary according to the quality of cable used and with the ability of individual installer/integrator.

**Tested with HD-SDI Receivers in the ProductionVIEW HD-SDI Console.

First Time Set-up with the HD-19:

The ClearVIEW HD-19 was designed to be exceptionally easy to use and operate. There is documentation at the back of the manual for pin-outs for all of the connectors on the ClearVIEW HD-19 camera.

Step 1: Using the HD Video Select Rotary Switch and Camera Settings Dip Switch on the back of the camera, set up the camera’s output resolution and functional preferences. There is a label on the bottom of the camera that identifies the choices.

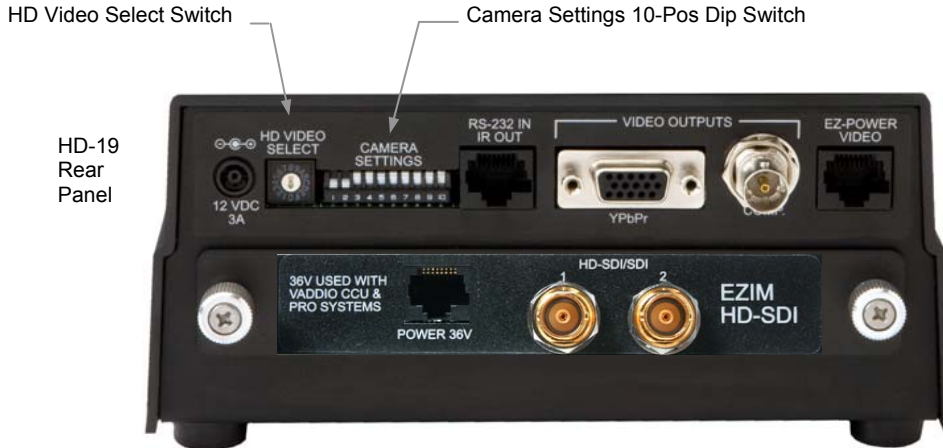

Label on the Bottom of HD-19

DIP SWITCH SETTINGS										HD VIDEO SELECT			
IR 1 1 & 2 UP	IR OUT OFF	9600 bps	SD NTSC	SD 4:3 6 & 7 UP	IMAGE FLIP OFF	TEST BARS OFF	10 OFF	0	720p/59.94	8	576i/25		
<input checked="" type="checkbox"/>	<input checked="" type="checkbox"/>	<input checked="" type="checkbox"/>	<input checked="" type="checkbox"/>	<input checked="" type="checkbox"/>	<input checked="" type="checkbox"/>	<input checked="" type="checkbox"/>	<input checked="" type="checkbox"/>	1	1080i/59.94	9	---		
<input checked="" type="checkbox"/>	<input checked="" type="checkbox"/>	<input checked="" type="checkbox"/>	<input checked="" type="checkbox"/>	<input checked="" type="checkbox"/>	<input checked="" type="checkbox"/>	<input checked="" type="checkbox"/>	<input checked="" type="checkbox"/>	2	1080p/59.94	A	---		
<input checked="" type="checkbox"/>	<input checked="" type="checkbox"/>	<input checked="" type="checkbox"/>	<input checked="" type="checkbox"/>	<input checked="" type="checkbox"/>	<input checked="" type="checkbox"/>	<input checked="" type="checkbox"/>	<input checked="" type="checkbox"/>	3	1080p/60	B	---		
<input checked="" type="checkbox"/>	<input checked="" type="checkbox"/>	<input checked="" type="checkbox"/>	<input checked="" type="checkbox"/>	<input checked="" type="checkbox"/>	<input checked="" type="checkbox"/>	<input checked="" type="checkbox"/>	<input checked="" type="checkbox"/>	4	720p/50	C	---		
<input checked="" type="checkbox"/>	<input checked="" type="checkbox"/>	<input checked="" type="checkbox"/>	<input checked="" type="checkbox"/>	<input checked="" type="checkbox"/>	<input checked="" type="checkbox"/>	<input checked="" type="checkbox"/>	<input checked="" type="checkbox"/>	5	1080i/50	D	---		
<input checked="" type="checkbox"/>	<input checked="" type="checkbox"/>	<input checked="" type="checkbox"/>	<input checked="" type="checkbox"/>	<input checked="" type="checkbox"/>	<input checked="" type="checkbox"/>	<input checked="" type="checkbox"/>	<input checked="" type="checkbox"/>	6	1080p/50	E	1080p/30		
<input checked="" type="checkbox"/>	<input checked="" type="checkbox"/>	<input checked="" type="checkbox"/>	<input checked="" type="checkbox"/>	<input checked="" type="checkbox"/>	<input checked="" type="checkbox"/>	<input checked="" type="checkbox"/>	<input checked="" type="checkbox"/>	7	480i/29.97	F	1080p/25		
IR 2 ON	IR 3 ON	ON	38400 bps	SD PAL	SD SQ	SD LB	ON	ON	ON				
1	2	3	4	5	6	7	8	9	10				

- Set the HD output resolution for the camera with the Rotary Switch.
- Set the IR frequency of the camera if it is to respond to the IR remote control.
- If using RS-232 for control, leave the IR OUT OFF (SW3) and choose 9600bps for most applications.
- If using the IR forwarding feature, turn the IR OUT ON (SW3).
- If inverting the camera, turn the IMAGE FLIP ON (SW8).

Dip Switch Settings:

IR 1 & 2: The IR remote has the capability of operating up to three different PTZ cameras from one remote. Use the selector buttons at the top of the IR remote to select the frequency.

IR Out 3: The IR output is sent out on the RS-232 RJ-45 jack on the back of the camera. Turning on the IR output will allow IR signals to be transmitted over the CAT-5 cable to the head end. When using RS-232 control or Vaddio CCU controllers (also via RS-232), turn the IR OUT to OFF.

Baud Rate 4: The options for baud rate are either 9600 bps or 38,400 bps. Default is 9600 bps.

SD Format 5: Choose between NTSC or PAL formats

SD Configurations 6 & 7: SD video can be set to standard 4:3, squeeze mode or letterbox mode.

Image Flip 8: To invert the HD-19, turn the IMAGE FLIP ON (switch down).

Test Bars 9: Turning on the non-standard test bars will override the camera video output. These non-standard test bars are 75% IRE.

Switch 10: Leave up - or in the OFF position

Installation Basics:

The WallVIEW CCU HD-19 camera was specifically designed for installation on a vertical wall surface with Cat-5e cable connectivity for Video, Power and Control signaling (three Cat-5e cables are required). Installation is simplified in that no custom 8-Pin mini-din cables or expensive plenum coax cables are needed and no power outlets are required near the camera bracket. All cabling is routed to the head-end using Cat-5e cables. "Pass-thru" type RJ-45 connectors should never be used (see notice on page 3 and comments below).

**Before Installing:**

- Locate the camera mounting location paying close attention to camera viewing angles, lighting conditions, possible line of site obstructions, and checking for in-wall obstructions where the camera is to be mounted. Pick a mounting location that will optimize the performance of the camera.
- The Thin Profile Wall Mount for the WallVIEW HD-19 can be mounted directly to a 2-gang wall box or can be mounted to the drywall using four dry wall anchors.
- Pre-wire all cabling as required, test and mark the cables POWER, VIDEO and CONTROL. Do not guess at the cable's function and try the "process of elimination method" and plug the POWER cable into all the RJ-45 jacks to see which one cable powers the camera. In all likelihood, this method will cause damage to your system and your warranty will be voided.

RS-232 Cabling:

- For RS-232, use a standard straight through RJ-45 connectors (568B termination) from the RS-232 port on the back of a Vaddio camera controller or switcher to the camera. If the camera is connected to a third-party control system (such as AMX or Crestron), a DB-9 to RJ-45 control adapter cable is supplied.
- **Please do not use "pass-thru" type RJ-45 connectors. The Vaddio Cat-5e wiring standard uses pins 7 and 8 on both the video and the control Cat-5e cables. The pass-through connectors have proven to provide insufficient connectivity for these important signals. They are "ok" for voice and data, but not for video and control.**

Videoconferencing Codecs and RS-232:

- Depending on the videoconferencing codec and RS-232 port used, special DB-9 to RJ-45 adapters may sometimes be required. Refer to Vaddio's price list or website for part numbers and codec compatibilities. Any special adapters and configuration information will be noted.
- **When using a videoconferencing system, remember to always power up the cameras before booting up the codec.**

Another Note about the IR OUT Dip Switch 4:

When operating the HD-19 camera with the Quick-Connect CCU, the IR OUT dip switch must be set to the OFF (up) position on the back of the camera. If it is not turned off, it can/will interfere with proper operation of the HD-19 PTZ camera. This would be, not so good, so please turn the IR OUT switch OFF.

Basic Installation Instructions:

Step 1:

After determining the optimum location of the camera system, route, mark and test the required two (2) Cat-5e cables and the HD-SDI coax from the camera to the Quick-Connect CCU Interface located at the head-end. The three Cat-5e cables should feed-through the oval slot located on the rear flange of the wall mount. If the bracket is to be mounted on a 2-gang wall box, use the screws supplied with the wall box cover plate to attach the Thin Profile Wall Mount. If mounting to the drywall with wall anchors, use four (4) provided drywall anchors. The mounting holes are slotted and are 90° opposing to provide easy leveling. Level the mount and tighten down the mounting screws.



Yet Another Note About the IR OUT Dip Switch 4:



When operating the HD-19 camera with the Quick-Connect CCU, the IR OUT dip switch must be set to the OFF (up) position on the back of the camera. If it is not turned off, it can and will interfere with proper operation of the HD-19 PTZ camera which, is never a good deal.

Step 2:

Follow the sample wiring diagram on the previous page for connecting the Cat-5e from the Quick-Connect CCU to the camera and to the switcher. Additional diagrams are available on our website for installation with other equipment.



REALLY IMPORTANT NOTE: Check all Cat-5e cables for continuity in advance of the final connection. Plugging the POWER Cat-5e Cable into the wrong RJ-45 may cause damage to the camera system and void the warranty.

Step 3:

Place the camera onto the camera mount, connect the previously marked and tested cables to their proper jacks (please do not guess - especially on the power Cat-5e). Slide the camera back onto the mount, “stuff” the extra cable back into the wall cavity (dress the cabling) and use the provided ¼” x 20 screws to attach the camera to the mount securely.

Step 4:

Connect the Vaddio 36 VDC, 2.78A power supply to the Quick-Connect CCU and then the AC side into an AC outlet. Power will travel down the Power Cat-5e cable to the camera. The camera will “Home” to a centered position ready for control information from CCU and the camera controller (ProductionVIEW HD or maybe the Precision Camera Controller). To ensure proper continuity of control and operation of the cameras, the boot order should be camera first (cameras are always first), the Quick-Connect CCU and lastly, the controller.

Step 5:

Set-up the CCU:

- Make sure that the HD video monitor that you are using is set up correctly and is delivering accurate color reproduction.
- Adjust the Iris level of the camera so that brighter areas are not washed out.
- Adjust the Brightness level to mid-range so that the black levels are not too dark, and not too light.
- Adjust the Red & Blue, Gain, Gamma, Detail and Chroma.

NOTE: Gain (next to Iris) should be left at 0 (zero), unless lighting is inadequate, then turn it to a level where the signal brightness is at an appropriate level. Gain adds additional noise (grain) to the video the higher it is turned up.

General Specifications:

WallVIEW CCU HD-19 HD-SDI High Definition PTZ Camera System	
Part Numbers	WallVIEW HD-19 North America 999-6948-000 (Black), 999-6948-000AW (Arctic White) WallVIEW HD-19 International 999-6948-001(Black), 999-6948-001AW (Arctic White)
Image Sensor	1/3-Type Exmor High-speed, Progressive Scan CMOS Sensor with 1.3 Megapixels
Video Output Resolutions	HD: 1080p/60/59.94/50/30/25, 1080i/59.94/50, 720p/59.94/50 SD: 480i/NTSC & 576i/PAL (Crop, Squeeze or Letterbox mode)
Lens/ Focal Length	19X Optical Zoom, F=4.5mm wide to 85mm tele end (F1.6-F2.9), Min. Focus Distance 1.0m
Horizontal Viewing Angle	58.1° Wide End to 3.2° Tele End - 16:9 Format
Video S/N Ratio	>52 dB
Minimum Illumination	0.7 LUX (F1.6, 50IRE)
Serial Control Protocol	RS-232 (Modified VISCA)
Pan Range	Pan: +170 degrees to -170 degrees, Tilt: +90 degrees to -30 degrees, Invertible for Ceiling Mount
Preset Positions	16 (internal), 6 recalled via IR Remote
Tally Light	Available through RS-232 Control
Connectors	<ul style="list-style-type: none"> 12 VDC Power Input: EIAJ-04 Coaxial Power Connector HD Video Outputs: YPbPr on DE-15 (D-Sub 15-pin HD) SD Video Output: BNC Connector RS-232/IR Out: RJ-45 Jack (RS-232 Communication and IR Out (with Quick-Connect -SR Interfaces) EZ Power HD Video: RJ-45 Jack, for use with Quick-Connect SR Interface or Quick-Connect DVI/HDMI SR Interface. Supplies power to the camera and returns HD video from the camera to the Quick-Connect - SR Systems.
HD Video Select	16-Position Rotary Switch: Used to set HD Video Resolution Output
Camera Settings	10-Position Dip Switch: Settings for IR Select, Baud Rate 9600, Image Flip, SD LB and SQ, Test Bars OSD (On Screen Display) for fine tuning
Accessories	Thin Profile Wall Mount 535-2000-230 (Black), 535-2000-230W (White) EZIM HD-SDI Slot Card PN# 998-6900-007 EZIM CCU Slot Card PN# 999-6900-006 - For Use with Quick-Connect CCU Only
Operating Temperature	32° to 104° F (0° to 40° C) / 20% to 80% Relative Humidity
Dimensions (H x W x D)	8.5" (215.9mm) H x 6.75" (171.45mm) W x 7.7" (195.58mm) D
Weight	5.79 lbs. (2.625635463kg.)

Quick-Connect CCU	
Connectors	Power Connector: 5.5mm OD x 2.5mm ID Power RJ-45: Supplies 36V to EZIM HD-SDI Slot Card RS-232 IN RJ-45: Accepts RS-232 (bi-directional) controller information RS-232 OUT RJ-45: Sends RS-232 (bi-directional) to camera G/L OUT: NA TALLY: 2-Pin Phoenix type spring cage connector BNC Connector for Sync (not available on HD-19) Video Outputs: Not used in this system configuration Video RJ-45: Not used in this system configuration
Controls	Scene: (A, B and C), Detail, Red Gain, Blue Gain, AWB, Shift key between Pedestal and Knee, Chroma, Gamma, Iris (Auto, Manual) and Gain
Camera Select Switch	All switches should be in the down position for HD-19
Video Adjustments	Y-Gain (luminance gain) for fine tuning over longer cable distances Distance Compensation: 100', 200', 300', 400'+ (Not used in this system configuration)
Cat-5e Cable Distance	Up to 500' (152.4m)
Power Supply	36 VDC, 2.78 Amp
Dimensions	1-RU Rack Mount - 1.75" (43.688) H x 18.93" (480.822mm) W x 6" (152.4mm) D
Thin Profile Wall Mount HD-19	
Materials	12-Gauge CRS with Black Powder Coat Paint
Dimensions	5.125" (130.175mm) H x 6.75" (171.45mm) W x 10" (254mm) D
Weight	Approx. 2.4 lbs. (1.08862176kg)
HD-SDI Slot Card	
Part Number	998-6900-007
Power Jack:	One (1) RJ-45, 36VDC used to Power Quick-Connect CCU over Cat-5e
HD-SDI Output:	Two (2) Outputs on BNC Connectors (Carrier Class, Gold Finish Body and Contacts, Circuit Board Edge Mount)
Slot Card Connection	One (1) 24-pin Self Guiding Blind Mating Interface Connector
HD-SDI Transmitter	High Speed HD-SDI/SDI transmitter, with integrated low noise VCO and integrated cable driver (polarizing imaging inducer not included - typical)
Dimensions:	With Connectors and Mounting Plate: 5.875" (149.23mm) W x 4.25" (107.95) D
Weight:	0.3lbs (.13607772 kg)

Compliance and CE Declaration of Conformity - ClearVIEW HD-19

Compliance testing was performed to the following regulations:

- **FCC Part 15, Subpart B** Class A
- **ICES-003, Issue 4: 2004** Class A
- **EN 55022 A: 2006 + A1: 2007(CISPR 22:2005/A1:2005)** Class A
- **AS/NZS CISPR 22: 2009 + A1: 2010** Class A
- **VCCI V-3/2010.04** Class A
- **EMC Directive 2004/108/EC** Class A



FCC Part 15 Compliance

This equipment has been tested and found to comply with the limits for a Class A digital device, pursuant to Part 15, Subpart B, of the FCC Rules. These limits are designed to provide reasonable protection against harmful interference when the equipment is operated in a commercial environment. This equipment generates, uses, and can radiate radio frequency energy and, if not installed and used in accordance with the instruction manual, may cause harmful interference to radio communications. Operation of this equipment in a residential area is likely to cause harmful interference in which case the user will be required to correct the interference at his/her own expense.

Operation is subject to the following two conditions: (1) This device may not cause interference, and (2) This device must accept any interference including interference that may cause undesired operation of the device. Changes or modifications not expressly approved by Vaddio can affect emission compliance and could void the user's authority to operate this equipment.



ICES-003 Compliance

This digital apparatus does not exceed the Class A limits for radio noise emissions from digital apparatus set out in the Radio Interference Regulations of the Canadian Department of Communications.

Le présent appareil numérique n'émet pas de bruits radioélectriques dépassant les limites applicables aux appareils numériques de la classe A prescrites dans le Règlement sur le brouillage radioélectrique édicté par le ministère des Communications du Canada.



European Compliance

This product has been evaluated for Electromagnetic Compatibility under the EMC Directive for Emissions and Immunity and meets the requirements for a Class A digital device. In a domestic environment this product may cause radio interference in which case the user may be required to take adequate measures.

Standard(s) To Which Conformity Is Declared:

EMC Directive 2004/108/EC

EN 55024: 1998 + Amendments A1: 2001 + A2: 2003

- | | |
|---|---|
| • EN 61000-4-2: 1995 + Amendments A1: 1998 + A2: 2001 | Immunity |
| • EN 61000-4-3: 2006 + A1: 2008 | Electrostatic Discharge |
| • EN 61000-4-4: 2004 + Corrigendum 2006 | Radiated Immunity |
| • EN 61000-4-5: 2006 | Electrical Fast Transients |
| • EN 61000-4-6: 2009 | Surge Immunity |
| • EN 61000-4-8: 2010 | Conducted Immunity |
| • EN 61000-4-11: Second Edition: 2004 | Power Frequency Magnetic Field |
| | Voltage Dips, Interrupts and Fluctuations |

Compliance and CE Declaration of Conformity - Quick-Connect CCU and EZIM HD-SDI

Compliance testing was performed to the following regulations:

- **FCC Part 15, Subpart B**
- **ICES-003, Issue 4: 2004**
- **European Standard EN 55022 A: 1998 + A1: 2000**
- **European Standard EN 55024: 1998 + Amendments A1: 2001 + A2: 2002**
- **EMC Directive 89/336/EC**

- Class A
- Class A
- Class A
- Class A
- Class A



FCC Part 15 Compliance

This equipment has been tested and found to comply with the limits for a Class A digital device, pursuant to Part 15, Subpart B, of the FCC Rules. These limits are designed to provide reasonable protection against harmful interference when the equipment is operated in a commercial environment. This equipment generates, uses, and can radiate radio frequency energy and, if not installed and used in accordance with the instruction manual, may cause harmful interference to radio communications. Operation of this equipment in a residential area is likely to cause harmful interference in which case the user will be required to correct the interference at his/her own expense.

Operation is subject to the following two conditions: (1) This device may not cause interference, and (2) This device must accept any interference including interference that may cause undesired operation of the device.

Changes or modifications not expressly approved by Vaddio can affect emission compliance and could void the user's authority to operate this equipment.



ICES-003 Compliance

This digital apparatus does not exceed the Class A limits for radio noise emissions from digital apparatus set out in the Radio Interference Regulations of the Canadian Department of Communications.

Le présent appareil numérique n'émet pas de bruits radioélectriques dépassant les limites applicables aux appareils numériques de la classe A prescrites dans le Règlement sur le brouillage radioélectrique édicté par le ministère des Communications du Canada.



European Compliance

This product has been evaluated for Electromagnetic Compatibility under the EMC Directive for Emissions and Immunity and meets the requirements for a Class A digital device. In a domestic environment this product may cause radio interference in which case the user may be required to take adequate measures.

Standard(s) To Which Conformity Is Declared: **Quick-Connect CCU**

EMC Directive 89/336/EC

EN 55022 A: 1998 + A1: 2000

EN 55024: 1998 + Amendments A1: 2001 + A2: 2002

- EN 61000-4-2:
- EN 61000-4-3:
- EN 61000-4-4:
- EN 61000-4-5:
- EN 61000-4-6:
- EN 61000-4-8:
- EN 61000-4-11

- Conducted and Radiated Emissions
- Immunity
- Electrostatic Discharge
- Radiated Immunity
- Electrical Fast Transients
- Surge Immunity
- Conducted Immunity
- Power Frequency Magnetic Field
- Voltage Dips, Interrupts and Fluctuations

Standard(s) To Which Conformity Is Declared: **EZIM HD-SDI Slot Card**

EMC Directive 2004/108/EC

EN 55022 A: 2006 + A1 2007 (CISPR 22:2005/A1:2005)

- AS/NZS CISPR 22: 2006, Australia and New Zealand
- VCCI V-3/2009.04, Japan

EN 55024: 1998 + Amendments A1: 2001 + A2: 2003

- EN 61000-4-2: 1995 + Amendments A1: 1998 + A2: 2001
- EN 61000-4-3: 2006
- EN 61000-4-4: 2004 + Corrigendum 2006
- EN 61000-4-5: 2006
- EN 61000-4-6: 2007
- EN 61000-4-8: 1993 + Amendment A1: 2001
- EN 61000-4-11 Second Edition: 2004

- Conducted and Radiated Emissions
- Conducted and Radiated Emissions
- Conducted and Radiated Emissions
- Electromagnetic Compatibility - Immunity
- Electrostatic Discharge
- Radiated Immunity
- Electrical Fast Transients
- Surge Immunity
- Conducted Immunity
- Power Frequency Magnetic Field
- Voltage Dips, Interrupts and Fluctuations

WARRANTY INFORMATION

(See Vaddio Warranty Policies posted on vaddio.com for complete details):

Hardware* Warranty: One year limited warranty on all parts. Vaddio warrants this product against defects in materials and workmanship for a period of one year from the day of purchase from Vaddio. If Vaddio receives notice of such defects during the warranty period, they will, at their option, repair or replace products that prove to be defective.

Exclusions: The above warranty shall not apply to defects resulting from: improper or inadequate maintenance by the customer, customer applied software or interfacing, unauthorized modifications or misuse, operation outside the normal environmental specifications for the product, use of the incorrect power supply, improper extension of the power supply cable or improper site operation and maintenance.

Vaddio Customer Service: Vaddio will test, repair, or replace the product or products without charge if the unit is under warranty and is found to be defective. If the product is out of warranty, Vaddio will test then repair the product or products. The cost of parts and labor charge will be estimated by a technician and confirmed by the customer prior to repair. All components must be returned for testing as a complete unit. Vaddio will not accept responsibility for shipment after it has left the premises.

Vaddio Technical Support: Vaddio technicians will determine and discuss with the customer the criteria for repair costs and/or replacement. Vaddio Technical Support can be contacted through one of the following resources: e-mail support at support@vaddio.com or online at www.vaddio.com.

Return Material Authorization (RMA) Number: Before returning a product for repair or replacement, request an RMA from Vaddio's technical support. Provide a technician with a return phone number, e-mail address, shipping address, and product serial numbers and describe the reason for repairs or returns as well as the date of purchase and proof of purchase. Include your assigned RMA number in all correspondence with Vaddio. Write your assigned RMA number on the shipping label of the box when returning the product. All returns are subject to a restocking fee without exception (see warranty policies at vaddio.com).

Voided Warranty: The warranty does not apply if the original serial number has been removed or if the product has been disassembled or damaged through misuse, accident, modifications, or unauthorized repair. Cutting the power supply cable on the secondary side (low voltage side) to extend the power to the device (camera or controller) voids the warranty for that device.

Shipping and Handling: Vaddio will not pay for inbound shipping transportation or insurance charges or accept any responsibility for laws and ordinances from inbound transit. Vaddio will pay for outbound shipping, transportation, and insurance charges for all items under warranty but will not assume responsibility for loss and/or damage by the outbound freight carrier. If the return shipment appears damaged, retain the original boxes and packing material for inspection by the carrier. Contact your carrier immediately.

Products Not Under Warranty: Payment arrangements are required before outbound shipment for all out of warranty products.

*Vaddio manufactures its hardware products from parts and components that are new or equivalent to new in accordance with industry standard practices.

Other General Information:

Care and Cleaning

Do not attempt to take this product apart at any time. There are no user-serviceable components inside.

- Do not spill liquids or liquid type substances onto the device.
- Keep this device away from food or liquid.
- For smears or smudges on the devices, wipe with a clean, soft cloth.
- Do not use any abrasive pads or caustic chemicals at any time on any Vaddio equipment.

Operating and Storage Conditions:

Do not store or operate the device under the following conditions:

- Temperatures above 40°C (104°F) or temperatures below 0°C (32°F)
- High humidity, condensing or wet environments
- In inclement weather
- Dusty environments
- In a swimming pool or water park
- Dry environments with an excess of static discharge
- Under severe vibration

Appendix 1: YPbPr Video Pin-Out for the HD-19 Camera & Quick-Connect Analog YPbPr Output

Pin	YPbPr
1	Pr
2	Y
3	Pb
4	-
5	-
6	Pr GND
7	Y GND
8	Pb GND
9	-
10	-
11	-
12	-
13	-
14	-
15	-

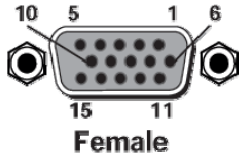

EZ POWER VIDEO RJ-45 Port Pin-Outs

Pin	YPbPr
1	Power+
2	Power-
3	Y+
4	PB+
5	PB GND
6	Y GND
7	PR+
8	PR-

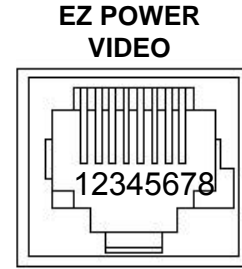

EZIM CCU Slot card Pin out Assignments (568B Wiring Standard)

Power Connector RJ-45

Pin	POWER
1	Power+
2	Power-
3	Power+
4	Power-
5	Power+
6	Power-
7	Power+
8	Power-

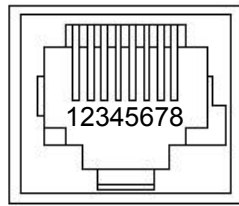

POWER



Appendix 2: ClearVIEW HD-19 Dimensions

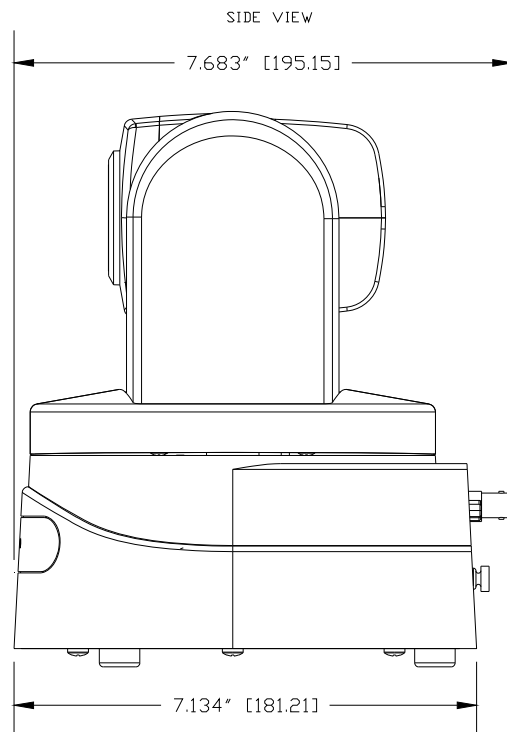
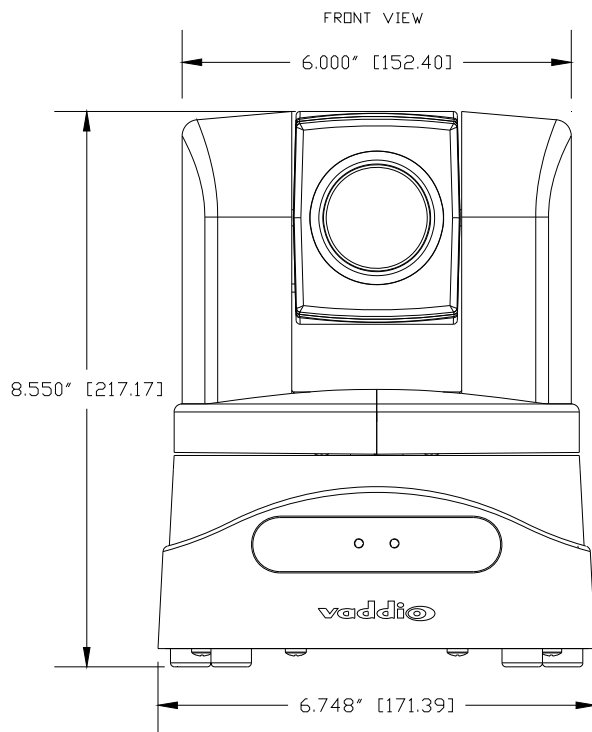

Appendix 3: Communication Specification

Communication Speed: 9600 bps (default)
 Start bit: 1
 Stop bit: 1
 Data bits: 8
 Parity: None
 No Flow control

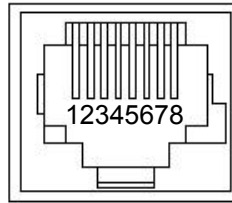

Pin #	RJ-45 RS-232 and IR Out Pins
1)	Unused
2)	Unused
3)	Unused
4)	IR Output (Diff Signal to Quick-Connect SR)
5)	IR Ground (Diff Signal to Quick-Connect SR)
6)	GND (GND of IR Short Range - Pin 3)
7)	RXD (from TXD of control source)
8)	TXD (to RXD of control source)

NOTE: The Vaddio ClearVIEW HD-19 Control Protocol is similar, but not identical to the Sony® VISCA™ command set in order to be compatible with several popular control devices. Not all VISCA commands are supported and there are many HD-19 specific commands in the following Command and Inquiry Lists.

HD-19 Command List (1/2)

Command Set	Command	Command Packet	Comments
Address Set	Broadcast	88 30 01 FF	Address Set (Daisy chain)
IF_Clear	Broadcast	88 01 00 01 FF	IF Clear
Command Cancel		8x 2p FF	p:socket number(1,2)
CAM_Power	On Off(Standby)	8x 01 04 00 02 FF 8x 01 04 00 03 FF	Power On/Off
CAM_Zoom	Stop Tele(Standard) Wide(Standard) Tele(Variable) Wide(Variable) Direct Direct(Variable)	8x 01 04 07 00 FF 8x 01 04 07 02 FF 8x 01 04 07 03 FF 8x 01 04 07 2p FF 8x 01 04 07 3p FF 8x 01 04 47 0p 0q 0r 0s FF 8x 01 7E 01 4A 0v 0p 0q 0r 0s FF	pqrs: Zoom Position* v:(Speed) 0-7
CAM_Focus	Stop Far(Standard) Near(Standard) Far(Variable) Near(Variable) AutoFocus ManualFocus Auto/Manual Direct	8x 01 04 08 00 FF 8x 01 04 08 02 FF 8x 01 04 08 03 FF 8x 01 04 08 2p FF 8x 01 04 08 3p FF 8x 01 04 38 02 FF 8x 01 04 38 03 FF 8x 01 04 38 10 FF 8x 01 04 48 0p 0q 0r 0s FF	pqrs: Focus position*
CAM_WB	Auto Manual One Push WB	8x 01 04 35 00 FF 8x 01 04 35 05 FF 8x 01 04 35 03 FF	
CAM_RGain	Reset Up Down Direct	8x 01 04 03 00 FF 8x 01 04 03 02 FF 8x 01 04 03 03 FF 8x 01 04 43 00 00 0p 0q FF	pq:00-ff
CAM_BGain	Reset Up Down Direct	8x 01 04 04 00 FF 8x 01 04 04 02 FF 8x 01 04 04 03 FF 8x 01 04 44 00 00 0p 0q FF	pq:00-ff
CAM_AE	Full Auto Manual Shutter Priority Iris Priority	8x 01 04 39 00 FF 8x 01 04 39 03 FF 8x 01 04 39 0A FF 8x 01 04 39 0B FF	Auto Exposure Mode Manual Control Mode Shutter Priority Mode Exposure Priority Mode (default)
CAM_Iris	Reset Up Down Direct	8x 01 04 0B 00 FF 8x 01 04 0B 02 FF 8x 01 04 0B 03 FF 8x 01 04 4B 00 00 0p 0q FF	pq(0x00-0x11)
CAM_Gain	Reset Up Down Direct	8x 01 04 0C 00 FF 8x 01 04 0C 02 FF 8x 01 04 0C 03 FF 8x 01 04 4C 00 00 0p 0q FF	pq(0x00-0x24)
CAM_Bright	Reset Up Down Direct	8x 01 04 0D 00 FF 8x 01 04 0D 02 FF 8x 01 04 0D 03 FF 8x 01 04 4D 00 00 0p 0q FF	pq(0x01-0x64)

HD-19 Command List (2/2)

Command Set	Command	Command Packet	Comments
CAM_Backlight	On	8x 01 04 33 02 FF	
	Off	8x 01 04 33 03 FF	
CAM_Aperture	Reset	8x 01 04 02 00 FF	
	Up	8x 01 04 02 02 FF	
	Down	8x 01 04 02 03 FF	
	Direct	8x 01 04 42 00 00 0p 0q FF	pq(0x00-0x1F)
CAM_Memory	Reset	8x 01 04 3F 00 0p FF	
	Set	8x 01 04 3F 01 0p FF	
	Recall	8x01 04 3F 02 0p FF	p:Memory No(=0-0xe)
CAM_IDWrite		8x 01 04 22 0p 0q 0r 0s FF	pqrs:0x0000 – 0xFFFF
IR_Receive	On	8x 01 06 08 02 FF	
	Off	8x 01 06 08 03 FF	
	On/Off	8x 01 06 08 10 FF	IR forwarding/Local IR
Pan-tiltDrive	Up	8x 01 06 01 VV WW 03 01 FF	WW: Pan Speed (0x01-0x18)
	Down	8x 01 06 01 VV WW 03 02 FF	VV:Tilt Speed(0x01-0x14)
	Left	8x 01 06 01 VV WW 01 03 FF	
	Right	8x 01 06 01 VV WW 02 03 FF	
	UpLeft	8x 01 06 01 VV WW 01 01 FF	
	UpRight	8x 01 06 01 VV WW 02 01 FF	
	DownLeft	8x 01 06 01 VV WW 01 02 FF	
	DownRight	8x 01 06 01 VV WW 02 02 FF	
	Stop	8x 01 06 01 VV WW 03 03 FF	
	Absolute Position	81 01 06 02 VV WW 0Y 0Y 0Y 0Y 0Z 0Z 0Z 0Z FF 0Y 0Y 0Y 0Y 0Z 0Z 0Z 0Z FF	YYYY: Pan Position** ZZZZ: Tilt Position**
	Home	8x 01 06 04 FF	
Reset	81 01 06 05 FF		
Tally	On	8x 01 7E 01 0A 00 02 FF	
	Off	8x 01 7E 01 0A 00 03 FF	
Preset Pan Speed	Pan/Tilt/Zoom Speed	81 01 7E 01 0B WW SS ZZ FF	WW: Pan Speed (0x01-0x18) SS:Tilt Speed(0x01-0x14) ZZ:Zoom Speed(0-7);
Motor Config	Hard Motor Stops	8x 01 7E 01 70 00 00 FF	
	Soft Motor Stops	8x 01 7E 01 70 00 01 FF	
BLK.Enhance	Pedestal	No Support	No Support
GMA.Enhance	Gamma	8x 01 7E 54 00 00 0p 0q FF	pq: Gamma (0x00-0x10)
CRM.Enhance	Chroma	8x 01 7E 55 00 00 0p 0q FF	pq: Chroma (0x00-0x64)
KNE.Enhance	Knee	No Support	No Support
DIS.Enhance	Digital Image	8x 01 7E 57 02 FF	On
	Stabilizer	8x 01 7E 57 03 FF	Off
SNR.Enhance	Super Noise	8x 01 7E 58 02 FF	On
	Reduction	8x 01 7E 58 03 FF	Off
AGC.Enhance	AGC Mode	8x 01 7E 59 00 FF	Off
		8x 01 7E 59 01 FF	Low
		8x 01 7E 59 02 FF	Medium
		8x 01 7E 59 03 FF	High
CAM_Shutter	Reset	8x 01 04 0A 00 FF	
	Up	8x 01 04 0A 02 FF	
	Down	8x 01 04 0A 03 FF	
	Direct	8x 01 04 4A 00 00 0p 0q FF	pq(0x00-0x23)
CAM_ExpComp	On	8x 01 04 3E 02 FF	AutoExposure Off
	Off	8x 01 04 3E 03 FF	AutoExpouse On
	Reset	8x 01 04 0E 00 FF	
	Up	8x 01 04 0E02 FF	
	Down	8x 01 04 0E 03 FF	
	Direct	8x 01 04 4E 00 00 0p 0q FF	Pq: 0x00-0x24
CAM_ICR Cut Filter	ICR On	8x 01 04 01 02 FF	ICR On - Cut Filter Out
	ICR Off	8x 01 04 01 03 FF	ICR Off - Cut Filter In

***Zoom and Focus Data:**

CAM_Zoom: Range(0x000–0x6B3)
 CAM_Focus: Range (0x000-0xC000) dependent on Zoom Position

****Additional Information:**

Pan Range: 8044 – 7FBC (-32,700 to +32,700)
 Tilt Range: E891 – 4C2B (-5,999 to +19,499)
 Actual Pan/Tilt ranges defined in Inquiry list

HD-19 Inquiry List (1/1)

Inquiry Command	Command	Response Packet	Comments
CAM_PowerInq	8x 09 04 00 FF	y0 50 02 FF y0 50 03 FF	On Off(Standby)
CAM_ZoomPosInq	8x 09 04 47 FF	y0 50 0p 0q 0r 0s FF	ppr: 0-0x6B3
CAM_FocusPosInq	8x 09 04 48 FF	y0 50 0p 0q 0r 0s FF	pprs: Focus Position
CAM_WBModelInq	81 09 04 35 FF	y0 50 00 FF y0 50 05 FF y0 50 03 FF	Auto Manual One Push WB
CAM_RGain	8x 09 04 43 FF	y0 50 00 00 0p 0q FF	pp:000-0ff
CAM_BGain	8x 09 04 44 FF	y0 50 00 00 0p 0q FF	pp:000-0ff
CAM_Iris	8x 09 04 4B FF	y0 50 00 00 0p 0q FF	pp(0x00-0x11)
CAM_Gain	8x 09 04 4C FF	y0 50 00 00 0p 0q FF	pp(0x00-0x24)
CAM_Bright	8x 01 04 4D FF	y0 50 00 00 0p 0q FF	pp(0x01-0x64)
CAM_BacklightModelInq	8x 09 04 33 FF	y0 50 02 FF y0 50 03 FF	On Off
CAM_ApertureInq	8x 09 04 42 FF	y0 50 00 00 0p 0q FF	Pq:x00-0x1F
CAM_MemoryInq	8x 09 04 3F FF	y0 50 0p FF	p:Preset 0-0xf
CAM_IDInq	8x 09 04 3F FF	y0 50 0p 0q 0r 0s FF	pprs:0x0000 – 0xFFFF
CAM_ReceiveInq	8x 09 06 08 FF	y0 50 02 FF y0 50 03 FF	On Off
Pan-TiltMaxSpeedInq	8x 09 06 11 FF	y0 50 pp qq FF	pp:Pan 0x01-0x18 qq:Tilt 0x01-0x14
Pan-tiltPositionInq	8x 09 06 12 FF	FF y0 50 0p 0p 0p 0p 0q 0q 0q 0q FF	pppp: Pan 0x8044-0x7FB2 qqqq: Tilt 0xE890-0x4C2C
TallyInq	8x 09 7E 01 0A FF	y0 50 02 FF y0 50 03 FF	On Off
PresetSpeedInq	8x 09 7E 01 0B FF	y0 50 pp qq rr FF	pp:Pan 0x01-0x18 qq:Tilt 0x01-0x14 rr:Zoom 0x00-0x07
Motor Config	8x 09 7E 01 70 FF	y0 50 00 FF y0 50 01 FF	Hard Motor Stops Soft Motor Stops
BLK.Enhance	No support	No Support	Pedestal
GMA.Enhance	8x 09 7E 54 FF	y0 50 00 00 0p 0q FF	pp: Gamma (0x00-0x10)
CRM.Enhance	8x 09 7E 55 FF	y0 50 00 00 0p 0q FF	pp: Chroma (0x00-0x64)
KNE.Enhance	No support	No Support	Knee
DIS.Enhance	8x 09 7E 57 FF	y0 50 02 FF y0 50 03 FF	On Off
SNR.Enhance	8x 09 7E 58 FF	y0 50 02 FF y0 50 03 FF	On Off
AGC.Enhance	8x 09 7e 59 FF	y0 50 00 FF y0 50 01 FF y0 50 02 FF y0 50 03 FF y0 50 04 FF	Off Low Medium High Manual AGC
CAM_AEModelInq	8x 09 04 39 FF	y0 50 00 FF y0 50 03 FF y0 50 0A FF y0 50 0B FF	Auto Exposure Mode Manual Control Mode Shutter Priority Mode Exposure Priority Mode
CAM_ShutterPosInq	8x 09 04 4A FF	y0 50 00 00 0p 0q FF	pp: 0x0-0x23
CAM_ExpCompModelInq	8x 09 04 3E FF	y0 50 02 FF y0 50 03 FF	On - AE Mode Off Off – AE Mode On
CAM_ExpCompPosInq	8x 09 04 4E FF	y0 50 00 00 0p 0q FF	pp: ExpComp Pos
CAM_ICRModelInq	8x 09 04 01 FF	y0 50 02 FF y0 50 03 FF	On - ICR filter Out Off – ICR filter In

Appendix 3 (continued):

Iris Position:

Index	F-Stop (Iris Position)
0x11	F1.6
0x10	F2.0
0x0F	F2.4
0x0E	F2.8
0x0D	F3.4
0x0C	F4.0
0x0B	F4.8
0x0A	F5.6
0x09	F6.8
0x08	F8.0
0x07	F9.6
0x06	F11.0
0x05	F14.0
0x04	F16.0
0x03	F19.0
0x02	F22.0
0x01	F28.0
0x00	Close

Gamma Position:

Index	Gamma value
0x10	1.00
0xF	0.95
0xE	0.90
0xD	0.85
0xC	0.80
0xB	0.75
0xA	0.70
0x9	0.65
0x8	0.60
0x7	0.55
0x6	0.50
0x5	0.45
0x4	0.40
0x3	0.35 (Default)
0x2	0.30
0x1	0.25
0x0	0.20

Shutter Position (Speed):

Index	Shutter (Speed)
0x23	1/30000
0x22	1/10000
0x21	1/5000
0x20	1/2500
0x1F	1/1500
0x1E	1/1000
0x1D	1/700
0x1C	1/600
0x1B	1/500
0x1A	1/480
0x19	1/360
0x18	1/300
0x17	1/250
0x16	1/240
0x15	1/200
0x14	1/180
0x13	1/150
0x12	1/120
0x11	1/100
0x10	1/60
0x0F	1/50
0x0E	1/30
0x0D	x2
0x0C	x4
0x0B	x6
0x0A	x8
0x09	x10
0x08	x12
0x07	x14
0x06	x16
0x05	x20
0x04	x24
0x03	x32
0x02	x40
0x01	x48
0x00	x60

Inside Back Cover - Blank

Touchboards

205 Westwood Ave, Long Branch, NJ 07740
Phone: 866-94 BOARDS (26273) / (732)-222-1511
Fax: (732)-222-7088 | E-mail: sales@touchboards.com

vaddio

9433 Science Center Drive, Minneapolis, MN 55428
Toll Free: 800-572-2011 • Phone: 763-971-4400 • FAX: 763-971-4464
www.vaddio.com